

**MEETING OF THE BOARD OF DIRECTORS
WATER REPLENISHMENT DISTRICT OF SOUTHERN CALIFORNIA
4040 PARAMOUNT BOULEVARD, LAKEWOOD, CALIFORNIA 90712**

9:00 A.M., FRIDAY, MARCH 20, 2009

AGENDA

Each item on the agenda, no matter how described, shall be deemed to include any appropriate motion, whether to adopt a minute motion, resolution, payment of any bill, approval of any matter or action, or any other action. Items listed as "For Information" or "For Discussion" may also be the subject of an "action" taken by the Board or a Committee at the same meeting.

1. DETERMINATION OF A QUORUM

2. PLEDGE OF ALLEGIANCE

3. ADDITIONAL ITEMS TO AGENDA

Determine the need to add items to the agenda. In order for the Board to add an item to the agenda it must make a determination that: (i). The item came to the attention of the Board after the posting of the agenda; (ii). That there is a need for immediate action to be taken by the Board. If these two tests are met, the Board may add the item in question to the agenda for consideration consistent with the provisions of the Brown Act.

4. PUBLIC COMMENT

5. CONSENT CALENDAR

Consent Calendar items are considered routine by the Board of Directors and will be adopted by one motion. There will be no separate discussion of these items unless a Board Member so requests, in which event the item will be removed from the Consent Calendar and considered separately immediately following action on the remaining items.

A. MINUTES OF THE MEETING OF JANUARY 16, 2009

B. MINUTES OF THE SPECIAL MEETING OF JANUARY 31, 2009

C. TRAVEL REQUEST – CARPE DIEM WESTERN WATER AND CLIMATE CHANGE PROJECT

External Affairs Committee Recommendation: Approve retroactively Director Lillian Kawasaki's out-of-state travel request to attend the Carpe Diem Western Water and Climate Change Project, March 4-6, 2009 in Nevada.

D. DEMANDS – JANUARY 31, 2009

Finance Committee Recommendation: Receive and file the Demands for January 31, 2009.

- E. FINANCIAL STATEMENTS – DECEMBER 31, 2008**
Finance Committee Recommendation: Approve the Financial Statements for December 31, 2008.
- F. INVESTMENT REPORT FOR THE PERIOD ENDING DECEMBER 31, 2008**
Finance Committee Recommendation: Approve the Investment Report for the period ending December 31, 2008.
- G. CONSIDERATION OF RESOLUTION NO. 09- 847 – A JOINT RESOLUTION OF THE BOARD OF SUPERVISORS OF THE COUNTY OF LOS ANGELES; THE BOARD OF DIRECTORS OF THE GREATER LOS ANGELES COUNTY VECTOR CONTROL DISTRICT; THE BOARD OF DIRECTORS OF THE COUNTY SANITATION DISTRICT NO. 8 OF LOS ANGELES COUNTY (COUNTY SANITATION DISTRICT NO. 8); THE CITY COUNCIL OF THE CITY OF CARSON; AND THE BOARD OF DIRECTORS OF THE WATER REPLENISHMENT DISTRICT OF SOUTHERN CALIFORNIA APPROVING AND ACCEPTING THE NEGOTIATED EXCHANGE OF PROPERTY TAX REVENUES RESULTING FROM ANNEXATION OF L 093-2008 TO COUNTY LIGHTING MAINTENANCE DISTRICT 1697**
Finance Committee Recommendation: Adopt Resolution No. 09-847.
- 6. CONSIDERATION OF RESOLUTION NO. 09-848 - A RESOLUTION OF THE BOARD OF DIRECTORS OF THE WATER REPLENISHMENT DISTRICT OF SOUTHERN CALIFORNIA ORDERING ACCEPTANCE AND FILING OF THE ENGINEERING SURVEY AND REPORT SUBMITTED PURSUANT TO SECTION 60300 OF THE WATER CODE, DECLARING THAT FUNDS SHALL BE RAISED FOR THE PURCHASE OF WATER FOR REPLENISHMENT AND FOR GROUNDWATER REPLENISHMENT AND QUALITY PROGRAMS AND PROJECTS DURING THE ENSUING FISCAL YEAR, THAT SUCH FUNDS SHALL BE RAISED BY A REPLENISHMENT ASSESSMENT AS PROVIDED IN SAID WATER CODE, DECLARING THAT THE FUNDS TO BE RAISED BY SAID REPLENISHMENT ASSESSMENT WILL BENEFIT, EITHER DIRECTLY OR INDIRECTLY, ALL OF THE PERSONS, REAL PROPERTY AND IMPROVEMENTS WITHIN THE DISTRICT, AND ORDERING THE PUBLICATION OF A NOTICE OF PUBLIC HEARING IN ACCORDANCE WITH SECTION 60306 OF THE WATER CODE**
Water Resources Committee Recommendation: Receive and file the 2009 Engineering Survey and Report and adopt Resolution No. 09-848.
- 7. STATE WATER RECYCLING POLICY ADOPTION – REPORT**
Water Resources Committee Recommendation: For information.

8. AWARD OF PROFESSIONAL SERVICES FOR SAFE DRINKING WATER PROGRAM

Groundwater Quality Committee Recommendation: The Groundwater Quality Committee reviewed this item on March 6, 2009. Due to a potential conflict of interest that the Committee Chair may have, the staff recommendation was deferred to the Board for their consideration.

9. WATER 101 FORUM

External Affairs Committee Recommendation: Approve the Water 101 Forum program, and direct staff to develop a budget including identification of partners to assist in funding the program for review by the External Affairs Committee.

10. ADMINISTRATIVE CODE REVISIONS – AMENDMENT TO SECTION 13.2.4 OF CHAPTER 10 OF THE WRD ADMINISTRATIVE CODE RELATING TO 10% REDUCTION OF TRAVEL BUDGET AND ENCUMBRANCE OF TRAVEL BUDGETS FOR MEMBERS OF THE BOARD OF DIRECTORS

Finance Committee Recommendation: Adopt Resolution No. 09-XXX, amending Section 13.2.4, entitled "Travel Expenses" of Chapter 13 of the Administrative Code to include provisions relating to 1) delete the requirement that the Board pre-approve any requests for out of state travel and 2) include provisions relating to encumbrance of Director's Travel Budget.

11. AWARD OF CONTRACT FOR OUTREACH SERVICES FOR THE SANITATION DISTRICTS OF LOS ANGELES COUNTY EARTH DAY EVENT

Board Recommendation: At the Special Board Meeting of March 6, 2009, the Board directed staff to bring the item to the regular meeting of March 20 for consideration by the Board.

12. MIDYEAR BUDGET REVIEW

Finance Committee Recommendation: For discussion.

13. WRD HISTORY REPORT

Staff Recommendation: For information.

14. GENERAL MANAGER'S REPORT

15. DISTRICT COUNSEL REPORT

16. COMMITTEE REPORTS

17. AB 1234 COMPLIANCE REPORTS AND DIRECTORS' REPORTS

18. WRD BOARD MEETING DATES

- A. April 3, 2009 – 9:00 a.m. – Board of Directors Meeting
- B. April 3, 2009 – 11:30 a.m. – Joint Board Meeting with Central Basin Municipal Water District
- C. April 17, 2009 – 9:00 a.m. – Board of Directors Meeting
- D. April 17, 2009 – 11:00 a.m. Joint Board Meeting with West Basin Municipal Water District
- E. May 1, 2009 – 9:00 a.m. – Board of Directors Meeting
- F. May 15, 2009 – 9:00 a.m. – Board of Directors Meeting

19. CLOSED SESSION

- A. Conference with Legal Counsel – Existing Litigation, pursuant to Government Code § 54956.9(a), California Water Service Company, et al. City of Compton, et al., Case No. 506 806
- B. Conference with Legal Counsel – Existing Litigation, pursuant to Government Code § 54956.9(a), Central and West Basin Water Replenishment District v. Charles Adams; L.A.S.C. Case No. 786,656
- C. Conference with Legal Counsel- Anticipated Litigation, pursuant to Government Code § 54956.9(b), One Case
- D. Labor Negotiations per Government Code §54957.6
Negotiator: Robb Whitaker
Bargaining Group: American Federation of State County & Municipal Employees (AFSCME)
Discussion: Terms and conditions for Memorandum of Understanding for bargaining group

20. ADJOURNMENT

Agenda posted by Abigail C. Andom, Deputy Secretary, March 17, 2009.

In compliance with the Americans with Disabilities Act (ADA), if special assistance is needed to participate in the Board meeting, please contact Deputy Secretary Abigail Andom at (562) 921-5521 for assistance to enable the District to make reasonable accommodations.

All public records relating to an agenda item on this agenda are available for public inspection at the time the record is distributed to all, or a majority of all, members of the Board. Such records shall be available at the District office located at 4040 Paramount Boulevard, Lakewood, California 90712.

Agendas and minutes are available at the District's website, www.wrd.org.

UNAPPROVED
MINUTES

UNAPPROVED
MINUTES

**MINUTES OF JANUARY 16, 2009
MEETING OF THE BOARD OF DIRECTORS
WATER REPLENISHMENT DISTRICT OF SOUTHERN CALIFORNIA**

A meeting of the Board of Directors of the Water Replenishment District of Southern California was held on January 16, 2009 at 9:10 a.m. in the District office located at 4040 Paramount Boulevard, Lakewood, California. President Robert Katherman called the meeting to order. Deputy Secretary Abigail C. Andom recorded the minutes.

1. INSTALLATION OF BOARD MEMBERS

President Katherman stated that the first order of business would be the installation of re-elected Director Albert Robles and himself. Director Sergio Calderon administered the oath of office to Directors Katherman and Robles.

2. DETERMINATION OF A QUORUM

President Katherman declared that a quorum of Directors was present, which in addition to himself included Directors Albert Robles and Sergio Calderon. Directors Lillian Kawasaki and Willard H. Murray, Jr. were excused.

3. PLEDGE OF ALLEGIANCE

Dan Massiello led the pledge of allegiance.

4. ADDITIONAL ITEMS TO THE AGENDA

Director Robles stated that he would like to add an item to the Board agenda, that there is an immediate need to take action on the item, and the item came to the attention of the Board after the posting of the agenda for today's meeting.

With no objections, it was

RESOLVED: The Board adds an item to the existing agenda, that the item came to the attention of the Board after the posting of the agenda for today's meeting, and that there is a need to take to take immediate action to discuss attendance to the National Groundwater Association training class to be held January 28-30, 2009, in Salt Lake City, Utah.

President Katherman stated that the item will be added to the agenda as Agenda Item 8.B.

5. PUBLIC COMMENT

None.

6. ELECTION OF OFFICERS

District Counsel Jamie Casso stated that Water Code §60154 states that the Board shall choose one of its members as president at its first meeting in January of each odd-numbered year. As such, Mr. Casso explained that it would be appropriate to have the election today, however, given the absence of two directors the election could be postponed until the next meeting of the Board.

Director Calderon stated that he would like to postpone the election today out of respect for the two directors that are not present.

Director Robles stated that the law is very specific that the election be held today at the Board's first meeting in the month of January of each odd-numbered year and that the Board should make an attempt to get at least three affirmative votes.

Discussion followed. Director Calderon made a motion to postpone the election to the next Board meeting. The motion was seconded by President Katherman.

By roll call vote, the motion failed for lack of a third vote.

AYES: Directors Calderon, Katherman

NOES: Director Robles

ABSENT: Directors Kawasaki, Murray

District Counsel Casso stated that based on the failed motion to postpone the vote to the next Board meeting, the floor is open for nominations for president of the Board. He noted that the nomination does not require a second.

Director Robles stated that he would like to nominate himself for the position of president of the Board.

President Katherman stated that he would like to nominate Director Kawasaki for the position of president of the Board.

By roll call vote, the nominations failed for lack of a third vote.

Calderon: Director Robles

Katherman: Director Kawasaki

Kawasaki: Absent

Murray: Absent

Robles: Director Robles

Director Calderon stated that he would like to nominate President Katherman for the position of president of the Board.

Director Robles stated that he would like to nominate himself for the position of president of the Board.

By roll call vote, the nominations failed for lack of a third vote.

Calderon: Director Katherman

Katherman: Director Katherman

Kawasaki: Absent
Murray: Absent
Robles: Director Robles

Director Robles stated that he would like to nominate himself for the position of president of the Board.

Director Calderon stated that he would like to nominate Director Murray for the position of president of the Board.

By roll call vote, the nominations failed for lack of a third majority vote.

Calderon: Director Murray
Katherman: Director Robles
Kawasaki: Absent
Murray: Absent
Robles: Director Robles

Director Calderon stated that he would like to nominate Director Robles for the position of president of the Board.

By roll call vote, it was unanimously

RESOLVED: That the Board elects Director Albert Robles as president of the Board.

Calderon: Director Robles
Katherman: Director Robles
Kawasaki: Absent
Murray: Absent
Robles: Director Robles

President Katherman congratulated President Robles and handed him the gavel to preside for the remainder of the meeting.

President Robles stated that he would like to nominate Director Katherman for the position of vice-president of the Board. With no objections, it was unanimously

RESOLVED: That the Board elects Director Rob Katherman as vice-president of the Board.

President Robles stated that he would like to nominate Director Calderon for the position of treasurer of the Board. With no objections, it was unanimously

RESOLVED: That the Board elects Director Sergio Calderon as treasurer of the Board.

Director Katherman stated that he would like to nominate Director Lillian Kawasaki for the position of Secretary of the Board. With no objections, it was unanimously

RESOLVED: That the Board elects Director Lillian Kawasaki as secretary of the Board.

7. CONSENT CALENDAR

- A. MINUTES OF THE SPECIAL MEETING OF NOVEMBER 24, 2008**
- B. DEMANDS – OCTOBER 31, 2008**
- C. DEMANDS – NOVEMBER 30, 2008**
- D. FINANCIAL STATEMENTS – AUGUST 31, 2008**
- E. FINANCIAL STATEMENTS – SEPTEMBER 30, 2008**
- F. INVESTMENT REPORTS FOR THE PERIODS ENDING AUGUST 31, 2008 AND SEPTEMBER 30, 2008**
- G. CPI ADJUSTMENT TO DEFERRED COMPENSATION**
- H. CONSIDERATION OF RESOLUTION NO. 09- 844– A JOINT RESOLUTION OF THE BOARD OF SUPERVISORS OF THE COUNTY OF LOS ANGELES; THE BOARD OF DIRECTORS OF THE GREATER LOS ANGELES COUNTY VECTOR CONTROL DISTRICT;**

THE BOARD OF DIRECTORS OF THE COUNTY SANITATION DISTRICT NO. 8 OF LOS ANGELES COUNTY (COUNTY SANITATION DISTRICT NO. 8); THE CITY COUNCIL OF THE CITY OF CARSON; AND THE BOARD OF DIRECTORS OF THE WATER REPLENISHMENT DISTRICT OF SOUTHERN CALIFORNIA APPROVING AND ACCEPTING THE NEGOTIATED EXCHANGE OF PROPERTY TAX REVENUES RESULTING FROM ANNEXATION OF PETITION NO. 62-608 TO COUNTY LIGHTING MAINTENANCE DISTRICT 1697

- I. CONSIDERATION OF RESOLUTION NO. 09- 845 – A JOINT RESOLUTION OF THE BOARD OF SUPERVISORS OF THE COUNTY OF LOS ANGELES; THE BOARD OF DIRECTORS OF THE GREATER LOS ANGELES COUNTY VECTOR CONTROL DISTRICT; THE BOARD OF DIRECTORS OF THE COUNTY SANITATION DISTRICT NO. 8 OF LOS ANGELES COUNTY (COUNTY SANITATION DISTRICT NO. 8); THE CITY COUNCIL OF THE CITY OF CARSON; AND THE BOARD OF DIRECTORS OF THE WATER REPLENISHMENT DISTRICT OF SOUTHERN CALIFORNIA APPROVING AND ACCEPTING THE NEGOTIATED EXCHANGE OF PROPERTY TAX REVENUES RESULTING FROM ANNEXATION OF L 064-2008 TO COUNTY LIGHTING MAINTENANCE DISTRICT 1697**
- J. BANK RESOLUTIONS**
- K. CONSIDERATION OF RESOLUTION NO. 09-846 – A RESOLUTION OF THE BOARD OF DIRECTORS OF THE WATER REPLENISHMENT DISTRICT OF SOUTHERN CALIFORNIA ORDERING AN ENGINEERING SURVEY AND REPORT REGARDING THE GROUNDWATER SUPPLIES OF THE DISTRICT PURSUANT TO WATER CODE §60300**
- L. REQUEST TO CO-SPONSOR LEGISLATION TO REGULATE WATER SOFTENERS**
- M. SUPPORT REAPPOINTMENT OF TAM M. DODUC TO THE STATE WATER RESOURCES CONTROL BOARD**

President Robles requested that Agenda Item 7.J be removed from the Consent Calendar.

Upon a motion duly made by Director Katherman, seconded by Director Calderon, and unanimously approved, it was

RESOLVED: That the Board approves the Consent Calendar of January 19, 2009, as amended.

7.J. BANK RESOLUTIONS

President Robles stated that he would like to refer the resolutions back to the Finance Committee. He explained that he would like to make sure that the procurement process to seek investment advisor services will not delay the action the Board took to begin banking relationships with the four designated financial institutions that reinvest and finance projects in communities the District services.

8. UPDATE OF PRE-QUALIFIED LIST OF TECHNICAL CONSULTANTS

General Manager Robb Whitaker stated that staff prepared a list of pre-qualified consultants on an as-needed basis for engineering, environmental and other technical services. Mr. Whitaker explained that the pre-qualified list made it possible for WRD to expedite the procurement process to obtain technical consultants. He noted that staff will be updating the list in the first quarter of 2009 and annually thereafter.

8.B. NATIONAL GROUNDWATER ASSOCIATION TRAINING, SALT LAKE CITY, JANUARY 28-30, 2009

Upon a motion duly made by President Robles, seconded by Director Katherman, and unanimously approved, it was

RESOLVED: The Board approves attendance of any interested director to the National Groundwater Association (NGWA) training class to be held January 28-20, 2009, in Salt Lake City, Utah.

9. REQUEST FOR PROPOSAL FOR PALOS VERDES DEWATERING AND GROUNDWATER RESUE STUDY

Chief Hydrogeologist Ted Johnson stated that the WRD and West Basin Municipal Water District (WBMWD) are jointly funding a study that would perform a fatal flaw analysis to determine if groundwater extracted from

two areas of the Palos Verdes Peninsula, specifically Abalone Cove and Malaga Cove Plaza, can be reused. Mr. Johnson noted that the reuse of the water would reduce demand for imported water within the service areas of both WRD and WBMWD. He stated that the study is estimated to cost between \$20,000 and \$40,000, which will be equally shared by both agencies.

Irving Pacheco, staff member of Assemblymember Ted Lieu, presented a certificate of congratulations to Director Katherman on his re-election to the WRD Board.

10. WRD HISTORY REPORT

District consultant Michael Gagan stated that this month's essay is titled: "Shaping the Institutional Structure for Replenishment in the Central and West Basins." Mr. Gagan discussed the events and circumstances that led to the formation of one replenishment district covering both basins. He also acknowledged the research assistance provided by GCG Rose and Kindel intern Jack Lopez, a graduate student of Cal State Fullerton.

11. GENERAL MANAGER'S REPORT

Mr. Whitaker congratulated the District's new officers. He noted that much work goes into facing today's water challenges and the importance of WRD's Water Independence Now (WIN) program which would eliminate the demand for imported water. He stated that he looks forward to working with the new officers.

12. DISTRICT COUNSEL REPORT

District Counsel Jamie Casso congratulated the new set of officers, and noted that his report will be provided in closed session.

13. COMMITTEE REPORTS

None.

14. AB 1234 COMPLIANCE REPORTS AND DIRECTORS' REPORTS

Director Calderon stated that he attended the Vernon Rotary Club Meeting on January 13 where he made a presentation on WRD. He also congratulated the new District officers.

Director Katherman stated that he attended the California Contract Cities Legislative Conference in Sacramento on January 12-14, 2009. He wished everyone happy new year, and congratulated the new officers.

Director Robles stated that he would like to thank his colleagues for their vote of confidence, and congratulated Director Katherman on his re-election to the Board. He thanked Mr. Gagan for his thorough report noting that 2008 and the coming years will be critical to the water industry. He stated that he is humbled and honored to serve as president of the Board during this critical time and asked everyone to keep up the good work.

15. WRD BOARD MEETING DATES

- A. February 20, 2009 – 9:00 a.m. – Board of Directors Meeting
- B. March 20, 2009 - 9:00 a.m. – Board of Directors Meeting
- C. April 17, 2009 – 9:00 a.m. – Board of Directors Meeting

16. CLOSED SESSION

- A. Conference with Legal Counsel – Existing Litigation, pursuant to Government Code §54956.9 (a), California Water Service Company, et al. City of Compton, et.al., Case No. 506 806
- B. Conference with Legal Counsel – Existing Litigation, pursuant to Government Code §54956.9 (a), Central and West Coast Basin Replenishment District v. Charles Adams; L.A.S.C. Case No. 786,656
- C. Conference with Legal Counsel – Anticipated Litigation, pursuant to Government Code §54956.9 (b): One Case
- D. Public Employee Performance Evaluation, pursuant to Government Code §54957
Title: General Manager

The Board went into closed session. The Board reconvened in open session.

District Counsel Casso stated that there was no reportable action on Agenda Items 16.A, 16.B, 16.C and 16.D.

17. ADJOURNMENT

President Robles asked if there was any further business to come before the Board, and there being none the meeting was adjourned at 12:15 p.m.

President

ATTEST:

Secretary

UNAPPROVED
MINUTES

UNAPPROVED
MINUTES

**MINUTES OF JANUARY 31, 2009
SPECIAL MEETING OF THE BOARD OF DIRECTORS
WATER REPLENISHMENT DISTRICT OF SOUTHERN CALIFORNIA**

A special meeting of the Board of Directors of the Water Replenishment District of Southern California was held on January 31, 2009 at 10:30 a.m. in the District office located at 4040 Paramount Boulevard, Lakewood, California. President Albert Robles called the meeting to order. Deputy Secretary Abigail C. Andom recorded the minutes.

1. DETERMINATION OF A QUORUM

President Robles declared that a quorum of Directors was present, which in addition to himself included Directors Sergio Calderon and Rob Katherman. Director Willard H. Murray, Jr. arrived while the meeting was in progress. Director Lillian Kawasaki was excused.

2. PUBLIC COMMENT

None.

3. PLANNING DISCUSSION

General Manager Robb Whitaker stated that the draft District Strategic Plan is before the Board today for review and adoption. Mr. Whitaker explained that the Strategic Plan includes the District's mission statement along with five goals and supporting objectives. He noted that staff, with direction from the Ad Hoc Executive Committee, has worked on the draft document over several months. He stated that it is also staff's intention to present the draft two-year workplan for the District. Mr. Whitaker stated that adoption of the WRD Strategic Plan would set the District's direction through clearly identified goals and objectives.

Director Murray arrived.

The Board reviewed the draft Strategic Plan document. Input was received on the goals and objectives.

The Board recessed at 12:00 p.m. for a short break. The Board reconvened at 12:20 p.m.

The Board directed the General Manager to make the recommended changes to the Strategic Plan and asked that the item be agendaized for the February Board meeting. The Board further directed the General Manager to develop the two-year workplan with specific tasks for each of the goals.

4. ADJOURNMENT

President Robles asked if there was any further business to come before the Board, and there being none the meeting was adjourned at 1:35 p.m.

President

ATTEST:

Secretary



MEMORANDUM

ITEM NO. 5.C

Prepared by: Elsa Lopez
Reviewed by: Abbie Andom
Approved by: Robb Whitaker

DATE: MARCH 20, 2009

TO: EXTERNAL AFFAIRS COMMITTEE

FROM: ROBB WHITAKER, GENERAL MANAGER

SUBJECT: TRAVEL REQUEST - CARPE DIEM WESTERN WATER AND CLIMATE CHANGE PROJECT

SUMMARY

The Carpe Diem project is an initiative with the mission to lay the groundwork to create a sustainable and equitable policy, legal, and regulatory framework to address the impact of climate change and the West's water resources, including those in California. WRD Director Lillian Kawasaki is a member of Carpe Diem's project team. The group met in Nevada on March 4 -6, 2009.

Attendees to the invitation-only event included representatives of water agencies, academia, philanthropy and environmental organizations. The meeting was hosted by the Southern Nevada Water Authority.

The External Affairs Committee met on February 18, 2009 and recommended the Board approve the participation and travel out-of-state by Director Kawasaki to attend the meeting. However, due to the timing of the meeting, the travel was too late to be agendaized for the February 20, 2009 Board meeting.

Section 13.2.4 of the District's Administrative Code allows for retroactive approval based on difficult or unexpected circumstances. Staff is seeking retroactive approval of the out-of-state travel.

FISCAL IMPACT

Travel and expenses are budgeted in the individual director's travel budget.

EXTERNAL AFFAIRS COMMITTEE RECOMMENDATION

Approve retroactively Director Lillian Kawasaki's out-of-state travel request to attend the Carpe Diem Western Water and Climate Change Project, March 4-6, 2009 in Nevada.



MEMORANDUM

ITEM NO. 5.D

*Prepared by: Binhyen Bui
Reviewed by: Scott M. Ota
Approved by: Robb Whitaker*

DATE: MARCH 20, 2009
TO: BOARD OF DIRECTORS
FROM: ROBB WHITAKER, GENERAL MANAGER
SUBJECT: DEMANDS – JANUARY 31, 2009

SUMMARY

At the request of the Finance Committee, the following items are attached:

- 1. The demands list for the period January 1st, 2009 – January 31st, 2009
- 2. The demands sorted by vendor with an additional column showing fiscal year-to-date payments

Demands Summary

Replenishment Fund	\$ 2,263,143.49
Clean Water Fund	<u>191,751.92</u>
Total	<u>\$ 2,454,895.41</u>

FINANCE COMMITTEE RECOMMENDATION

Receive and file the Demands for January 31, 2009.



DIRECTORS

ALBERT ROBLES, PRESIDENT
 ROBERT KATHERMAN, VICE PRESIDENT
 LILLIAN KAWASAKI, SECRETARY
 SERGIO CALDERON, TREASURER
 WILLARD H. MURRAY, JR., DIRECTOR

ROBB WHITAKER, P.E. GENERAL MANAGER

March 20, 2009

Board of Directors
 Water Replenishment District of Southern California

Submitted herewith for action by the Board of Directors are the following demands for the period ending January,2009.

Check #	Payee	Description	Total	Replenishment Fund	Clean Water Fund
DD	ALBERT ROBLES	12/08 DIRECTORS COMPENSATION	668.16	628.07	40.09
DD	ALBERT ROBLES	12/08 EXPENSE REIMBURSEMENT	779.76	732.97	46.79
DD	ALBERT ROBLES	01/09 DIRECTORS COMPENSATION	2,884.06	2,711.02	173.04
DD	SERGIO J. CALDERON	12/08 DIRECTORS COMPENSATION	648.33	609.43	38.90
DD	SERGIO J. CALDERON	01/09 DIRECTORS COMPENSATION	621.26	583.98	37.28
DD	WILLARD H. MURRAY, JR	11/08 DIRECTORS COMPENSATION	610.95	574.28	36.67
DD	WILLARD H. MURRAY, JR	11/08 EXPENSE REIMBURSEMENT	54.59	51.31	3.28
DD	ROBERT KATHERMAN	12/08 DIRECTORS COMPENSATION	941.54	885.05	56.49
24300	ROBERT KATHERMAN	12/08 EXPENSE REIMBURSEMENT	1,097.77	1,031.92	65.85
24301	ROBERT KATHERMAN	12/08 EXPENSE REIMBURSEMENT	550.16	517.15	33.01
24302	LILLIAN Y. KAWASAKI	09/08 DIRECTORS COMPENSATION	552.52	519.35	33.17
24303	LILLIAN Y. KAWASAKI	10/08 DIRECTORS COMPENSATION	528.82	497.09	31.73
24304	LILLIAN Y. KAWASAKI	EXPENSE REIMBURSEMENT	437.36	411.12	26.24
DD	AFSCME LOCAL 1902 UNION	PAYROLL DEDUCTION PAYMENT	492.20	418.08	74.12
DD	AFSCME LOCAL 1902 UNION	PAYROLL DEDUCTION PAYMENT	492.20	404.47	87.73
DD	EDD	DIR STATE TAX PAYMENT	11.19	10.52	0.67
DD	EDD	STATE TAX PAYMENT	4,480.56	3,902.97	577.59
DD	EDD	STATE TAX PAYMENT	4,463.66	3,693.43	770.23
DD	PRUDENTIAL INSURANCE	DEFERRED COMPENSATION	20,381.19	18,086.69	2,294.50
DD	PRUDENTIAL INSURANCE	DEFERRED COMPENSATION	20,381.19	16,531.36	3,849.83
DD	PRUDENTIAL INSURANCE	DIR DEFERRED COMPENSATION	9,140.34	8,591.94	548.40
DD	PRUDENTIAL INSURANCE	DIR DEFERRED COMPENSATION	2,550.00	2,397.01	152.99
DD	EMPLOYEE PAYROLL	SALARY EXPENSE	62,220.47	53,851.72	8,368.75
DD	EMPLOYEE PAYROLL	SALARY EXPENSE	67,741.65	56,520.60	11,221.05
DD	IRS	FEDERAL TAX PAYMENT	28,837.32	25,157.99	3,679.33
DD	IRS	FEDERAL TAX PAYMENT	28,805.64	23,754.50	5,051.14
DD	IRS	DIR FEDERAL TAX PAYMENT	2,075.21	1,950.71	124.50
DD	IRS	DIR FEDERAL TAX PAYMENT	1,033.54	971.54	62.00
DD	PERS	PERS PAYMENT	27,629.51	24,113.74	3,515.77
DD	PERS	PERS PAYMENT	27,629.51	22,808.43	4,821.08
DD	PERS	DIRECTORS' PERS PYMT	650.53	611.50	39.03
DD	PERS	DIRECTORS' PERS PYMT	654.31	615.06	39.25
DD	PARS	DIRECTORS' PARS PYMT	2,568.99	2,414.84	154.15
DD	PARS	DIRECTORS' PARS PYMT	986.65	927.45	59.20
ACH081107	WBMWD	11/08 WATER PURCHASE	691,371.08	691,371.08	-
ACH090129	US BANK TRUST N.A.	12/08-01/09 INTEREST EXPENSE	319,446.67	300,279.88	19,166.79
24305	LAKEWOOD SELF STORAGE	1/5/09-12/31/09 STORAGE RENTAL	2,971.50	2,793.22	178.28
24306	THE CASTLE PRESS	2008 NEWSLETTER POSTAGE	22,801.29	21,245.21	1,356.08
24307	STETSON ENGINEERS	011: 09/07 PROF SERVICE	5,779.91	2,889.96	2,889.95
24308	ACCOMTEMP	TEMP SERVICE THRU 12/26/08	2,752.80	2,587.63	165.17
24309	CALIFORNIA WATER SERVICE	MONTHLY WATER USAGE	54.82	51.53	3.29
24310	F&M BANK: CC PAYMENT	12/08 DIR MURRAY CC CHR	750.00	705.00	45.00
24311	FEDERAL EXPRESS	FEDEX SERVICE	108.12	108.12	-
24312	HELPMATES STAFFING	TEMP SERVICE THRU 12/28/08	1,974.72	1,856.23	118.49
24313	LOS ANGELES, CITY OF DWP	10/20/08-11/19/08 WATER PURCHASE	15,364.80	15,364.80	-
24314	LOS ANGELES COUNTY DPW	004: PERMIT FEES	450.00	450.00	-
24315	M ARTHUR GENSLER	032: PROF SERVICE THRU 11/29/08	17,788.46	16,721.15	1,067.31
24316	MONO LAKE COMMITTEE	EDUCATIONAL SCHOOL TRIPS	10,000.00	9,400.00	600.00
24317	OFFICE TEAM	TEMP SERVICE THRU 12/26/08	1,849.00	1,738.06	110.94
24318	PACIFIC FORD	011: F250 TRUCK REPAIR SVC	40.38	20.19	20.19
24319	STANDARD INSURANCE	01/09 STD/LTD PREMIUM	1,465.00	1,377.10	87.90
24320	STEPHEN-FOSSLER	50th ANNIVERSARY STICKERS	334.59	314.51	20.08
24321	VERIZON WIRELESS	MONTHLY CELL PHONE SVC	1,155.29	1,085.98	69.31
24322	XEROX CORPORATION	12/08 COPIER SERVICE	5,138.97	4,830.64	308.33
24323	SEE PAYROLL	SEE PAYROLL	-	-	-
24324	GOGREEN EXPO LLC	EXPO BOOTH REGISTRATION	5,980.00	5,621.20	358.80
24325	1-800-CONFERENCE(R)	CONFERENCE CALLS	220.93	207.67	13.26
24326	ACWA1	12/08-01/09 EAP PREMIUM	340.56	320.16	20.40
24327	ADT SECURITY SERVICES	2/1/09-12/31/09 MAINT SERVICE	973.26	914.86	58.40
24328	AT&T	002: MONTHLY PHONE SVC	322.15	-	322.15
24329	CAPITOL ENQUIRY	PREVIEW DIRECTORY	17.03	16.01	1.02
24330	CHEVRON AND TEXACO	12/08 FUEL CHARGES	25.00	12.50	12.50
24331	COSTCO	KITCHEN SUPPLIES	359.65	338.07	21.58
24332	FEDERAL EXPRESS	FEDEX SERVICE	269.26	218.91	50.35
24333	GEORGE CHEVROLET	011: S10 TRUCK REPAIR SVC	1,386.32	693.16	693.16
24334	GEOTECH ENVIRONMENTAL	011: FIELD SUPPLIES	1,875.33	937.67	937.66
24335	GRNDWATER RESOURCES ASSOC	2009 MEMBERSHIP DUES	100.00	50.00	50.00
24336	INGLEWOOD AIRPT CHAMBER	2009 MEMBERSHIP DUES	300.00	282.00	18.00
24337	LA EXPRESS ONE	COURIER SERVICE	106.90	100.49	6.41
24338	LAKEWOOD CHAMBER	12/1/08-1/30/09 MEMB DUES	400.00	376.00	24.00
24339	LEGISLATIVE ADVOCACY	11/08 LEGISLATIVE SERVICE	7,500.00	7,050.00	450.00

Check #	Payee	Description	Total	Replenishment Fund	Clean Water Fund
24343	OFFICE TEAM	TEMP SERVICE THRU 10/10/08	172.00	161.68	10.32
24344	PARS	11/08 REP FEES	500.00	470.00	30.00
24345	PBCC	1/20/09-4/20/09 METER LEASE	1,282.76	1,205.80	76.96
24346	POSTAGE BY PHONE	POSTAGE DEPOSIT	2,000.00	1,880.00	120.00
24347	ROSE & KINDEL	12/08 LEGISLATIVE SERVICE	15,158.45	14,548.94	609.51
24348	SANTA FE SPRINGS	1/1/09-12/31/09 MEMB DUES	220.00	206.80	13.20
24349	SCHLUMBERGER	001: DATALOGGERS HARDWARE	550.00	550.00	-
24350	SOUTHERN CALIFORNIA EDISON	12/08 ENERGY USAGE	7,159.09	3,406.67	3,752.42
24351	STAR OFFICE PRODUCTS	OFFICE SUPPLIES	1,226.96	1,153.34	73.62
24352	TGIS CATERING SERVICES	KAREN BASS BRIEFING	537.25	505.02	32.23
24353	VOID	VOID	-	-	-
24354	US FIRE PROTECTION	FIRE EXTINGUISHER MAINT SVC	166.50	156.51	9.99
24355	VASQUEZ & COMPANY LLP	2007-08 FINAN AUDIT SERVICE	4,700.00	4,418.00	282.00
24356	VERIZON CALIFORNIA	MONTHLY PHONE CHARGES	341.84	321.33	20.51
24357	VERNON CHAMBER	2009 MEMBERSHIP DUES	350.00	329.00	21.00
24358	WATER EDUCATION FOUNDATION	2009 MEMBERSHIP DUES	661.00	621.34	39.66
24359	WESTERN EXTERMINATOR	12/08 PESTICIDE SERVICE	65.00	61.10	3.90
24360	XEROX CORPORATION	01/09 COPIER SERVICE	3,444.26	3,237.61	206.65
24361	THOMSON WEST	2009 CA CODE BOOKS	1,000.14	940.13	60.01
24362	JENNA SHAUNESSY FOR WRD	PETTY CASH REIMB	395.02	372.22	22.80
24363	ROBERT W. GOLDSWORTHY	MEDICAL REIMBURSEMENT	444.99	418.29	26.70
24364	VOID	VOID	-	-	-
24365	LOS ANGELES COUNTY DPW	PERMIT FEE-PCFA 200500477	125.00	125.00	-
24366	LOS ANGELES COUNTY DPW	PERMIT FEE-PCFA 200504294	125.00	125.00	-
24367	F&M BANK: CC PAYMENT	12/08 CC CHARGES	6,130.59	5,762.77	367.82
24368	HELPMATES STAFFING	TEMP SERVICE THRU 12/14/08	1,196.80	1,124.99	71.81
24369	SEE PAYROLL	SEE PAYROLL	-	-	-
24370	ACWA1	02/09 EAP PREMIUM	116.82	109.82	7.00
24371	ACWA - HBA	02/09 MED/DEN/LIFE PREMIUM	41,407.90	38,923.43	2,484.47
24372	EXXON MOBIL	MONTHLY FUEL CHARGES	229.15	229.15	13.75
24373	INTER-TEL NETSOLUTIONS	MONTHLY PHONE CHARGES	821.00	771.74	49.26
24374	MARTIN E WHELAN, JR.	02/09 MEDICAL PREMIUM	740.09	695.68	44.41
24375	PHILLIPS 66-CONOCO-76	MONTHLY FUEL SERVICE	240.58	161.17	79.41
24376	STANDARD INSURANCE	02/09 STD/LTD PREMIUM	1,465.00	1,377.10	87.90
24377	ACCOUNTEMPS	TEMP SERVICE THRU 1/09/09	2,844.56	2,673.89	170.67
24378	AIR RENTAL	AC RENTAL UNIT	150.00	141.00	9.00
24379	BZ DISPOSAL SERVICES	01/09 WASTE SERVICE	176.23	165.66	10.57
24380	CAMP DRESSER & McKEE	001: PROF SERVICE THRU 11/1/08	10,673.00	10,673.00	-
24381	CDW GOVERNMENT	COMPUTER SUPPLIES	930.18	874.37	55.81
24382	CONTROLLED KEY SYSTEM	MAINTENANCE SERVICE	449.88	422.89	26.99
24383	COUNTY SANITATION DISTRICT 2	10/08 WATER PURCHASE - SJC	45,607.06	45,607.06	-
24384	COUNTY SANITATION DISTRICT 2	10/08 WATER PURCHASE - WN	1,986.60	1,986.60	-
24385	SOUTHWEST WATER COMPANY	002: 12/08 O & M SERVICE	19,876.18	-	19,876.18
24386	FEDERAL EXPRESS	FEDEX SERVICE	67.80	67.80	-
24387	HARBOR CITY/GATEWAY CHAMBER	INSTALLATION LUNCHEON	450.00	423.00	27.00
24388	HELPMATES STAFFING	TEMP SERVICE THRU 1/11/09	1,937.32	1,821.09	116.23
24389	IN-SITU INC.	011: EQUIP MAINT SERVICE	3,413.87	1,706.91	1,706.96
24390	VOID	VOID	-	-	-
24391	INTERIOR PLANT DESIGN	01/09 PLANT MAINT SERVICE	1,025.00	899.50	125.50
24392	LOMITA CHAMBER	INSTALLATION DINNER	500.00	470.00	30.00
24393	LOS ANGELES, CITY OF DWP	11/19/08-12/19/08 WATER PURCHASE	149,628.60	149,628.60	-
24394	MANPOWER	TEMP SERVICE THRU 1/11/09	166.98	156.96	10.02
24395	M ARTHUR GENSLER	032: PROF SERVICE THRU 12/27/08	25,534.43	24,002.36	1,532.07
24396	MERRIL COMMUNICATION	PROFESSIONAL SERVICE	4,943.28	4,646.68	296.60
24397	MWH LABORATORIES	10/08 & 11/08 LAB SERVICES	175,242.00	121,396.00	53,846.00
24398	NELLOR ENVIRONMENTAL	004: 12/08 PROF SERVICE	2,340.00	2,340.00	-
24399	OFFICE TEAM	TEMP SERVICE THRU 1/9/09	2,300.50	2,162.47	138.03
24400	VOID	VOID	-	-	-
24401	K & L GATES	11/08 PROF SERVICE	15,000.00	14,100.00	900.00
24402	K & L GATES	10/08 PROF SERVICE	15,000.00	14,100.00	900.00
24403	PRUDENTIAL INSURANCE	2008 ADMIN FEES - 2401	3,466.00	3,258.04	207.96
24404	PRUDENTIAL INSURANCE	2008 ADMIN FEES - 2403	2,400.00	2,256.00	144.00
24405	ROBERT E. BUSH	12/08 PROF SERVICE	3,000.00	2,820.00	180.00
24406	SANTA FE SPRINGS	ADMIN FEES	50.00	47.00	3.00
24407	SCORPIO ENTERPRISES	032: 12/08 CONS SERVICE	216,472.50	203,484.15	12,988.35
24408	SOFTWARE TRAINING CENTER	REGISTRATION FEE - TF	290.00	272.60	17.40
24409	TESTAMERICA	12/08 PROF SERVICE	10,616.00	-	10,616.00
24410	THE GAS COMPANY	MONTHLY UTILITY CHRGS	1,178.17	1,107.48	70.69
24411	TORRANCE, CITY OF	002: 02/09 PLANT SITE RENT	3,373.48	-	3,373.48
24412	ALSTON & BIRD	12/08 LEGAL SERVICE	22,119.09	22,119.09	-
24413	WILMINGTON CHAMBER	INSTALLATION & GALA EVENT	2,000.00	1,880.00	120.00
24414	XO CORPORATION	PHONE CHARGE THRU 2/14/09	94.21	88.56	5.65
24415	INDEPENDENT CITIES ASSOC	CONF REGIS FEE - AR & RK	900.00	846.00	54.00
24416	VOID	VOID	-	-	-
24417	PARS	IRS LETTER OF DETERMINATION	1,000.00	940.00	60.00
24418	MONROE ALEXANDER	MAINTENANCE SERVICE	1,153.94	1,084.70	69.24
24419	EXXON MOBIL	01/09 FUEL CHARGES	500.00	470.00	30.00
Total Demands from January 1, 2009 to January 31, 2009			2,454,895.41	2,263,143.49	191,751.92

Robb Whitaker, P.E., General Manager

Water Replenishment District of Southern California
 Demands List - Current and YTD By Vendor

<u>Payee</u>	<u>Description</u>	<u>Current Demands</u>	<u>YTD Demands</u>
PAYROLL	BENEFIT/DEDUCTION/REIMBURSEMENT	113,556.62	779,109.44
PAYROLL	PAYROLL	129,962.12	1,146,981.80
PAYROLL	TAXES	69,707.12	510,286.51
ALBERT ROBLES	12/08 DIRECTORS COMPENSATION	668.16	13,784.10
ALBERT ROBLES	12/08 EXPENSE REIMBURSEMENT	779.76	3,671.27
ALBERT ROBLES	01/09 DIRECTORS COMPENSATION	2,884.06	16,668.16
SERGIO J. CALDERON	12/08 DIRECTORS COMPENSATION	648.33	5,225.51
SERGIO J. CALDERON	01/09 DIRECTORS COMPENSATION	621.26	3,075.76
ROBERT KATHERMAN	12/08 DIRECTORS COMPENSATION	941.54	5,343.06
ROBERT KATHERMAN	12/08 EXPENSE REIMBURSEMENT	1,097.77	4,071.09
ROBERT KATHERMAN	12/08 EXPENSE REIMBURSEMENT	550.16	4,621.25
WILLARD H. MURRAY, JR.	11/08 DIRECTOR COMPENSATION	610.95	2,461.19
WILLARD H. MURRAY, JR.	11/08 EXPENSE REIMBURSEMENT	54.59	107.63
LILLIAN Y. KAWASAKI	09/08 DIRECTORS COMPENSATION	552.52	2,137.48
LILLIAN Y. KAWASAKI	10/08 DIRECTORS COMPENSATION	528.82	2,666.30
LILLIAN Y. KAWASAKI	EXPENSE REIMBURSEMENT	437.36	8,396.69
1-800-CONFERENCE(R)	CONFERENCE CALLS	220.93	3,087.58
ACCONTEMPS	TEMP SERVICE THRU 1/09/09	2,844.56	24,142.14
ACCONTEMPS	TEMP SERVICE THRU 12/26/08	2,752.80	26,894.94
ACWA - HBA	02/09 MED/DEN/LIFE PREMIUM	41,407.90	298,641.39
ACWA1	02/09 EAP PREMIUM	116.82	540.57
ACWA1	12/08-01/09 EAP PREMIUM	340.56	881.13
ADT SECURITY SERVICES	2/1/09-12/31/09 MAINT SERVICE	973.26	1,592.62
AIR RENTAL	AC RENTAL UNIT	150.00	150.00
ALSTON & BIRD	12/08 LEGAL SERVICE	22,119.09	224,253.50
AT&T	002: MONTHLY PHONE SVC	322.15	1,630.28
BZ DISPOSAL SERVICES	01/09 WASTE SERVICE	176.23	1,404.54
CALIFORNIA WATER SERVICE	MONTHLY WATER USAGE	54.82	363.29
CAMP DRESSER & McKEE	001: PROF SERVICE THRU 11/1/08	10,673.00	10,673.00
CAPITOL ENQUIRY	PREVIEW DIRECTORY	17.03	409.61
CDW GOVERNMENT	COMPUTER SUPPLIES	930.18	11,046.43
CHEVRON AND TEXACO	12/08 FUEL CHARGES	25.00	2,387.20
CONTROLLED KEY SYSTEM	MAINTENANCE SERVICE	449.88	3,261.46
COSTCO	KITCHEN SUPPLIES	359.65	2,625.77
COUNTY SANITATION DISTRICT 2	10/08 WATER PURCHASE - SJC	45,607.06	531,556.33
COUNTY SANITATION DISTRICT 2	10/08 WATER PURCHASE - WN	1,986.60	533,542.93
EXXON MOBIL	01/09 FUEL CHARGES	500.00	2,755.72
EXXON MOBIL	MONTHLY FUEL CHARGES	229.15	2,984.87
F&M BANK: CC PAYMENT	12/08 CC CHARGES	6,130.59	36,150.75
F&M BANK: CC PAYMENT	12/08 DIR MURRAY CC CHRG	750.00	36,900.75
FEDERAL EXPRESS	FEDEX SERVICE	269.26	3,022.45
FEDERAL EXPRESS	FEDEX SERVICE	67.80	3,090.25
FEDERAL EXPRESS	FEDEX SERVICE	108.12	3,198.37
GEORGE CHEVROLET	011: S10 TRUCK REPAIR SVC	1,386.32	1,386.32
GEOTECH ENVIRONMENTAL	011: FIELD SUPPLIES	1,875.33	7,951.40
GOGREEN EXPO LLC	EXPO BOOTH REGISTRATION	5,980.00	5,980.00
GRNDWATER RESOURCES ASSOC	2009 MEMBERSHIP DUES	100.00	100.00
HARBOR CITY/GATEWAY CHAMBER	INSTALLATION LUNCHEON	450.00	625.00
HELPMATES STAFFING	TEMP SERVICE THRU 1/11/09	1,937.32	46,063.16
HELPMATES STAFFING	TEMP SERVICE THRU 12/14/08	1,196.80	47,259.96
HELPMATES STAFFING	TEMP SERVICE THRU 12/28/08	1,974.72	49,234.68
INDEPENDENT CITIES ASSOC	CONF REGIS FEE - AR & RK	900.00	900.00
INGLEWOOD AIRPT CHAMBER	2009 MEMBERSHIP DUES	300.00	300.00
IN-SITU INC.	011: EQUIP MAINT SERVICE	3,413.87	22,147.85
INTERIOR PLANT DESIGN	01/09 PLANT MAINT SERVICE	1,025.00	7,865.39
INTER-TEL NETSOLUTIONS	MONTHLY PHONE CHARGES	821.00	6,586.04
JENNA SHAUNESSY FOR WRD	PETTY CASH REIMB	395.02	1,539.41
K & L GATES	10/08 PROF SERVICE	15,000.00	121,775.63
K & L GATES	11/08 PROF SERVICE	15,000.00	136,775.63
LA EXPRESS ONE	COURIER SERVICE	106.90	951.94
LAKEWOOD CHAMBER	12/1/08-11/30/09 MEMB DUES	400.00	880.00
LAKEWOOD SELF STORAGE	1/5/09-12/31/09 STORAGE RENTAL	2,971.50	15,151.52
LEGISLATIVE ADVOCACY	11/08 LEGISLATIVE SERVICE	7,500.00	52,500.00
LOMITA CHAMBER	INSTALLATION DINNER	500.00	850.00

Water Replenishment District of Southern California
 Demands List - Current and YTD By Vendor

<u>Payee</u>	<u>Description</u>	<u>Current Demands</u>	<u>YTD Demands</u>
LONG BEACH, CITY OF	001: 11/08 O & M SERVICE	166,914.39	2,541,542.70
LOS ANGELES COUNTY DPW	004: PERMIT FEES	450.00	1,050.00
LOS ANGELES COUNTY DPW	PERMIT FEE-PCFA 200500477	125.00	1,175.00
LOS ANGELES COUNTY DPW	PERMIT FEE-PCFA 200504294	125.00	1,300.00
LOS ANGELES, CITY OF DWP	10/20/08-11/19/08 WATER PURCHASE	15,364.80	939,938.67
LOS ANGELES, CITY OF DWP	11/19/08-12/19/08 WATER PURCHASE	149,628.60	1,089,567.27
M ARTHUR GENSLER	032: PROF SERVICE THRU 11/29/08	17,788.46	20,030.96
M ARTHUR GENSLER	032: PROF SERVICE THRU 12/27/08	25,534.43	45,565.39
MANPOWER	TEMP SERVICE THRU 1/11/09	166.98	166.98
MARTIN E WHELAN. JR.	02/09 MEDICAL PREMIUM	740.09	5,928.74
MERRIL COMMUNICATION	PROFESSIONAL SERVICE	4,943.28	4,943.28
MONO LAKE COMMITTEE	EDUCATIONAL SCHOOL TRIPS	10,000.00	10,000.00
MONROE ALEXANDER	MAINTENANCE SERVICE	1,153.94	2,227.94
MR ROOTER PLUMBING	WATER HEATER REPAIR SVC	443.04	1,144.04
MWH LABORATORIES	10/08 & 11/08 LAB SERVICES	175,242.00	473,805.00
NELLOR ENVIRONMENTAL	004: 12/08 PROF SERVICE	2,340.00	10,710.00
OFFICE TEAM	TEMP SERVICE THRU 1/9/09	2,300.50	18,210.50
OFFICE TEAM	TEMP SERVICE THRU 10/10/08	172.00	18,382.50
OFFICE TEAM	TEMP SERVICE THRU 12/26/08	1,849.00	20,231.50
PACIFIC FORD	011: F250 TRUCK REPAIR SVC	40.38	1,707.09
PARS	11/08 REP FEES	500.00	4,000.00
PARS	IRS LETTER OF DETERMINATION	1,000.00	5,000.00
PBCC	1/20/09-4/20/09 METER LEASE	1,282.76	3,848.28
PHILLIPS 66-CONOCO-76	MONTHLY FUEL SERVICE	240.58	5,713.25
POSTAGE BY PHONE	POSTAGE DEPOSIT	2,000.00	5,000.00
PRUDENTIAL INSURANCE	2008 ADMIN FEES - 2401	3,466.00	3,466.00
PRUDENTIAL INSURANCE	2008 ADMIN FEES - 2403	2,400.00	5,866.00
ROBERT E. BUSH	12/08 PROF SERVICE	3,000.00	21,000.00
ROBERT W. GOLDSWORTHY	MEDICAL REIMBURSEMENT	444.99	444.99
ROSE & KINDEL	12/08 LEGISLATIVE SERVICE	15,158.45	105,984.69
SANTA FE SPRINGS	1/1/09-12/31/09 MEMB DUES	220.00	220.00
SANTA FE SPRINGS	ADMIN FEES	50.00	270.00
SCHLUMBERGER	001: DATALOGGERS HARDWARE	550.00	64,176.75
SCORPIO ENTERPRISES	032: 12/08 CONS SERVICE	216,472.50	258,525.00
SOFTWARE TRAINING CENTER	REGISTRATION FEE - TF	290.00	580.00
SOUTHERN CALIFORNIA EDISON	12/08 ENERGY USAGE	7,159.09	122,121.81
SOUTHWEST WATER COMPANY	002: 12/08 O & M SERVICE	19,876.18	240,848.60
STANDARD INSURANCE	01/09 STD/LTD PREMIUM	1,465.00	9,528.00
STANDARD INSURANCE	02/09 STD/LTD PREMIUM	1,465.00	10,993.00
STAR OFFICE PRODUCTS	OFFICE SUPPLIES	1,226.96	10,253.42
STEPHEN-FOSSLER	50th ANNIVERSARY STICKERS	334.59	334.59
STETSON ENGINEERS	011: 09/07 PROF SERVICE	5,779.91	5,779.91
TESTAMERICA	12/08 PROF SERVICE	10,616.00	58,300.45
TGIS CATERING SERVICES	KAREN BASS BRIEFING	537.25	537.25
THE CASTLE PRESS	2008 NEWSLETTER POSTAGE	22,601.29	58,065.94
THE GAS COMPANY	MONTHLY UTILITY CHRGS	1,178.17	6,410.29
THOMSON WEST	2009 CA CODE BOOKS	1,000.14	1,608.46
TORRANCE, CITY OF	002: 02/09 PLANT SITE RENT	3,373.48	63,255.02
US BANK TRUST N.A.	12/08-01/09 INTEREST EXPENSE	319,446.67	959,044.42
US FIRE PROTECTION	FIRE EXTINGUISHER MAINT SVC	166.50	166.50
VASQUEZ & COMPANY LLP	2007-08 FINAN AUDIT SERVICE	4,700.00	31,700.00
VERIZON BUSINESS	MONTHLY INTERNET SERVICE	533.00	4,797.00
VERIZON CALIFORNIA	MONTHLY PHONE CHARGES	341.84	2,753.18
VERIZON WIRELESS	MONTHLY CELL PHONE SVC	1,155.29	9,777.08
VERNON CHAMBER	2009 MEMBERSHIP DUES	350.00	350.00
WATER EDUCATION FOUNDATION	2009 MEMBERSHIP DUES	661.00	1,236.00
WBMWD	11/08 WATER PURCHASE	691,371.08	5,700,113.24
WESTERN EXTERMINATOR	12/08 PESTICIDE SERVICE	65.00	1,165.00
WILMINGTON CHAMBER	INSTALLATION & GALA EVENT	2,000.00	2,340.00
XEROX CORPORATION	01/09 COPIER SERVICE	3,444.26	32,168.04
XEROX CORPORATION	12/08 COPIER SERVICE	5,138.97	37,307.01
XO CORPORATION	PHONE CHARGE THRU 2/14/09	94.21	860.53
		2,454,895.41	17,866,156.30



MEMORANDUM

ITEM NO. 5.E

Prepared by: Scott M. Ota

Reviewed by: Scott M. Ota

Approved by: Robb Whitaker

DATE: MARCH 20, 2009
TO: BOARD OF DIRECTORS
FROM: ROBB WHITAKER, GENERAL MANAGER
SUBJECT: FINANCIAL STATEMENTS – DECEMBER 31, 2008

The attached financial statements include the Statement of Net Assets (Balance Sheet) as of December 31, 2008 and the Statement of Revenues, Expenditures and Changes in Net Assets (Income Statement) for the month ending December 31, 2008. Explanation of selected account balances are as follows:

Statement of Net Assets

ASSETS

Cash – The increase of approximately \$1.9 million in December; was primarily due to the timing of the receipt of District assessment payments. There is a corresponding decrease in accounts receivable.

Accounts Receivable – Accounts receivable decreased \$1.5 million because of the timing of payment related to the groundwater replenishment assessment. There is a corresponding increase in cash.

LIABILITIES

Accounts Payable – Increased approximately \$439,000 mainly due to construction services and the air conditioning improvement for the District’s administration building. In addition, the increase was resulted from the professional services relating to conjunctive use and the annual fees for waste discharge requirements from State Water Resources Control Board.

NET ASSETS

Invested in Capital Assets – This is a formula and is related to the changes in all capital asset accounts:

<u>Accounts</u>	<u>Change</u>
Plant & Equipment	\$ 0
Construction-In-Progress	336,114
Accumulated Depreciation	(188,756)
Total	<u>\$ (147,358)</u>

Unrestricted – The Change/Variance of Total Assets, Total Liabilities and Invested in Capital Assets from November to December 2008 was \$729,129.

Statement of Revenues, Expenditures and Changes in Net Assets

REVENUE

Water Replenishment Assessment - Decreased \$260,000 in December due to seasonal reduction of groundwater usage.

MWD Subsidy, OCWD Recycled Water Product and the LJVWTF Lease Revenue – These accounts all increased because the District received payment for November and December in the month of December.

EXPENSES

Injected Water – Increased \$318,000 in December was simply due to a small increase in water purchased for injection at the West Coast Barrier.

FISCAL IMPACT

None.

FINANCE COMMITTEE RECOMMENDATION

Approve the Financial Statements for December 31, 2008.

Water Replenishment District of Southern California
Statement of Net Assets
December 31, 2008

Assets	Total	Prior Month Total	Variance
Current Assets			
Cash and Cash Equivalents	\$ 19,961,978	\$ 17,995,117	1,966,861
Restricted Cash	10,456,645	10,532,643	(75,998)
Accounts Receivable	7,504,632	9,087,844	(1,583,213)
Deposits Receivable	144,005	144,005	-
Interest Receivable	113,984	113,984	-
Prepaid Expenses	85,758	97,154	(11,396)
Total Current Assets	\$ 38,267,002	\$ 37,970,747	296,255
Noncurrent Assets			
Notes Receivable, Noncurrent	\$ 1,785,513	\$ 1,785,513	-
Plant & Equipment	60,886,082	60,886,082	-
Land	2,644,753	2,644,753	-
Construction-In-Progress	4,879,311	4,543,197	336,114
Deferred Charges	459,775	459,775	-
Accumulated Depreciation	(12,280,541)	(12,091,785)	(188,756)
Total Noncurrent Assets	\$ 58,374,893	\$ 58,227,535	147,358
Total Assets	\$ 96,641,895	\$ 96,198,282	443,613
Liabilities			
Current Liabilities			
Accounts Payable	\$ 3,795,128	\$ 4,181,807	(386,678)
Interest Payable - Bond	266,378	213,102	53,276
Accrued Payroll	301	(623)	924
Accrued Employee Benefits	(41,351)	(26,238)	(15,113)
Accrued Postemployment	455,925	455,925	-
Deferred Compensation	5,325	5,325	-
Cal Trans 0690	6,206,147	6,291,429	(85,282)
Long term Debt - Bond Payable	14,785,000	14,785,000	-
Other Liabilities	430,400	430,400	-
Total Current Liabilities	\$ 25,903,253	\$ 26,336,127	(432,874)
Noncurrent Liabilities			
Compensated Absences	\$ 237,931	\$ 237,931	-
Total Noncurrent Liabilities	\$ 237,931	\$ 237,931	-
Total Liabilities	\$ 26,141,184	\$ 26,574,058	(432,874)
Net Assets			
Invested in Capital Assets	\$ 56,129,605	\$ 55,982,247	147,358
Unrestricted	14,371,106	13,641,977	729,129
Total Net Assets	\$ 70,500,711	\$ 69,624,224	876,487
Total Liabilities & Net Assets	\$ 96,641,895	\$ 94,625,882	2,016,013

Water Replenishment District of Southern California
Statement of Revenues, Expenditures and Changes in Net Assets
For the Month of December 2008

	Total	Prior Month Total	Variance
Revenues			
Operating Revenues			
Water Replenishment Assessments	2,648,598	2,908,876	(260,277)
Late Payment Penalties	-		-
MWD Subsidy	56,428	-	56,428
OCWD Recycled Water Product	149,630	-	149,630
Desalter Revenue	-	-	-
LJVWFT Lease	230,433	115,217	115,217
Title 22 Monitoring Program	40,850		40,850
Total Operating Revenues	<u>3,125,940</u>	<u>3,024,092</u>	<u>101,848</u>
Operating Expenses			
Cost of Water			
Spreading	7,817	-	7,817
Injected	1,228,808	910,366	318,442
In-Lieu	-	-	-
Connection Fees	83,911	12,928	70,983
Total Cost of Water	<u>1,320,536</u>	<u>923,294</u>	<u>397,242</u>
General & Administrative			
Salaries, Taxes & Benefits	544,744	314,277	230,468
Postemployment Benefits	-	-	-
Conference & Travel	11,090	9,033	2,057
Office Expenses	58,002	57,333	669
Utilities	12,428	12,518	(90)
Rents & Leases	4,904	5,682	(778)
Repairs & Maintenance	40,329	34,498	5,831
Material & Equipment	4,585	6,326	(1,740)
General Liability Insurance	11,396	11,396	-
Professional Fees	250,267	434,735	(184,468)
Other General & Administrative	-	1,050	(1,050)
Total General & Administrative	<u>937,746</u>	<u>886,847</u>	<u>50,899</u>
Depreciation	188,756	188,756	-
Total Operating Expenses	<u>2,447,038</u>	<u>1,998,897</u>	<u>448,141</u>
Operating Income (Loss)	<u>678,902</u>	<u>1,025,195</u>	<u>(346,293)</u>
Non-Operating Revenues (Expenses)			
Revenues			
Property Taxes	177,602	15,998	161,603
Investment Earnings	6,196	45,834	(39,638)
Miscellaneous	4,504	4,993	(489)
Total Non-Operating Revenues (Expenses)	<u>188,301</u>	<u>66,825</u>	<u>121,476</u>
Income (Loss) Before Contributions	867,203	1,092,020	(224,817)
Contributions			
Capital Contributions- Caltran Grant	9,284		9,284
Change in Net Assets	<u>876,487</u>	<u>1,092,020</u>	<u>(215,533)</u>



MEMORANDUM

ITEM NO. 5.F

Prepared by: Scott M. Ota

Reviewed by: Scott M. Ota

Approved by: Robb Whitaker

DATE: MARCH 20, 2009

TO: BOARD OF DIRECTORS

FROM: ROBB WHITAKER, GENERAL MANAGER

SUBJECT: INVESTMENT REPORT FOR THE PERIOD ENDING DECEMBER 31, 2008

Each month, the Finance Department reports the investment activities of the District to the Finance Committee for subsequent approval by the Board of Directors. Staff has attached the investment report for December 31, 2008 for approval by the Board of Directors.

FISCAL IMPACT

None.

FINANCE COMMITTEE RECOMMENDATION

Approve the Investment Report for the period ending December 31, 2008.

**Water Replenishment District
Cash & Investments
December 31, 2008**

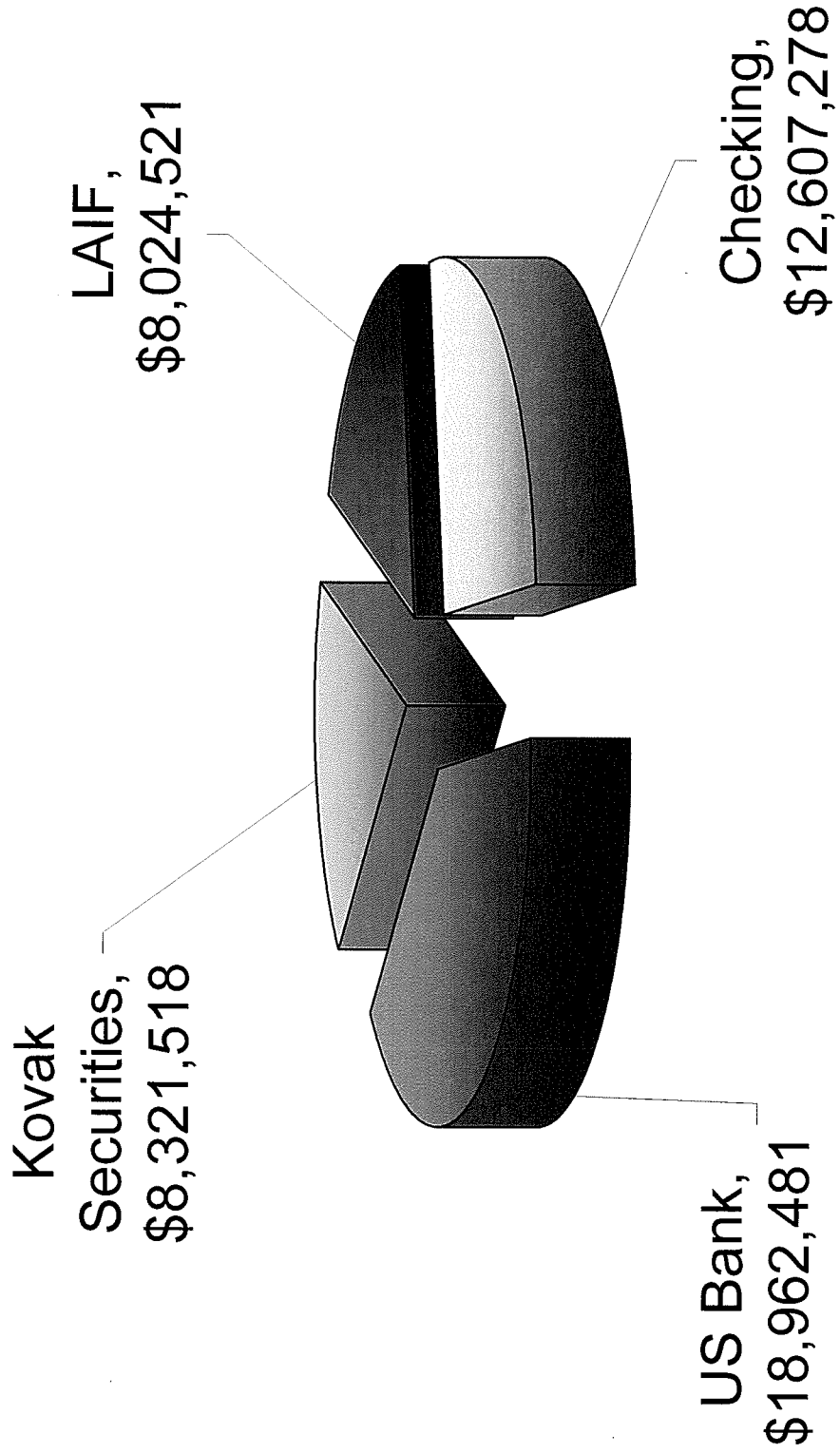

Water Replenishment District Investment Type Breakdown as of December 31, 2008

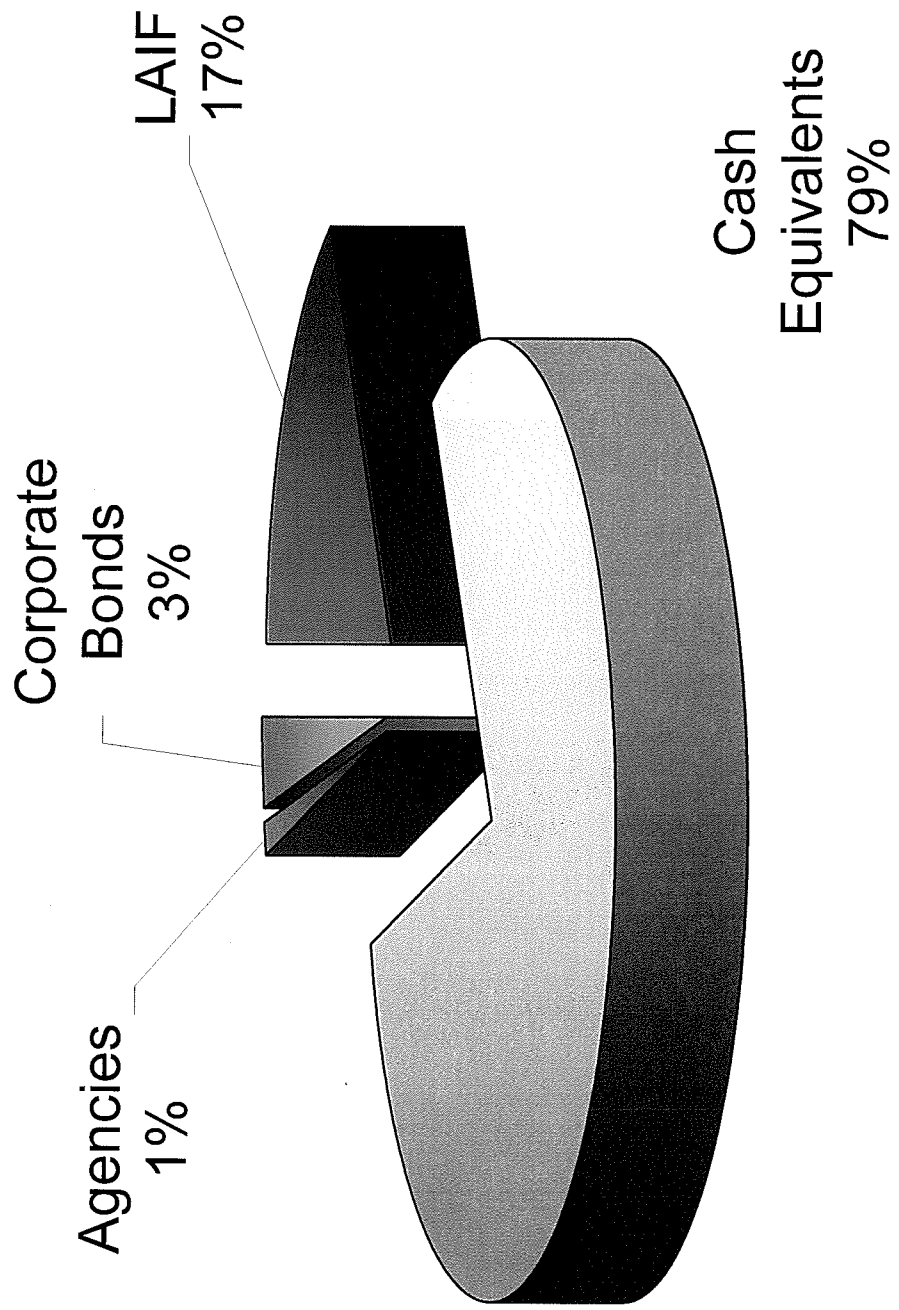

December 2008
Portfolio Analysis

12/31/08

Account # K4K 065900

Purchase Date	Symbol/USIP	Security Description	CPN	Last CPN	Maturity Date	Days to Maturity	Closing Quantity	Recent Price	Recent Market Value	Bond	Coef Interest	Total	Unpaid Interest (UPI)	Market Value and UPI				
CERTIFICATES OF DEPOSITS																		
10/15/08		1ST FED BANK-SANTA MONICA	2.600%		1/21/09	21	95,009.50	\$1,000	95,000.00	95,009.50	67.67	95,071.17	67.67	95,067.67				
10/15/08		B OF A - CHARLOTTE NC	2.400%		1/22/09	22	95,009.50	\$1,000	95,000.00	95,009.50	62.47	95,071.97	62.47	95,069.47				
10/15/08		BRANCH BKG & TR CO	2.450%		1/22/09	22	95,009.50	\$1,000	95,000.00	95,009.50	63.77	95,073.27	63.77	95,063.77				
10/15/08		GOLDMAN SACHS USA	2.400%		1/22/09	22	95,009.50	\$1,000	95,000.00	95,009.50	63.77	95,073.27	63.77	95,063.77				
10/15/08		LAKE CITY BK - IND	2.400%		1/23/09	23	95,009.50	\$1,000	95,000.00	95,009.50	62.47	95,071.97	62.47	95,062.47				
10/15/08		GE MONEYS BK - UT	2.500%		1/23/09	23	95,009.50	\$1,000	95,000.00	95,009.50	58.56	95,068.06	58.56	95,058.56				
10/15/08		NEW CENTY BK - PA	2.500%		1/23/09	23	95,009.50	\$1,000	95,000.00	95,009.50	52.05	95,061.55	52.05	95,052.05				
10/16/08		BANCO BILBAO	2.500%		1/27/09	27	95,009.50	\$1,000	95,000.00	95,009.50	32.53	95,042.03	32.53	95,032.53				
10/16/08		TRUMPH BK - TN	2.500%		2/17/09	47	95,009.50	\$1,000	95,000.00	95,009.50	110.62	95,121.12	110.62	95,110.62				
10/15/08		COLE TAYLOR BK - IL	2.600%		2/23/09	53	95,009.50	\$1,000	95,000.00	95,009.50	67.67	95,071.17	67.67	95,063.25				
10/15/08		ROCKBRIDGE COML BK - GA	2.700%		2/23/09	53	95,009.50	\$1,000	95,000.00	95,009.50	63.25	95,072.75	63.25	95,063.25				
10/15/08		TIDELANDS BK - SC	2.550%		2/23/09	53	95,009.50	\$1,000	95,000.00	95,009.50	73.01	95,082.51	73.01	95,073.01				
10/15/08		REPUBLIC BK - KY	2.650%		3/2/09	62	95,009.50	\$1,000	95,000.00	95,009.50	20.69	95,030.19	20.69	95,020.69				
TOTAL CERTIFICATES OF DEPOSIT \$										1,235,123.50	\$	796.53	\$	1,235,796.53				
US TREASURY / AGENCY SECURITIES																		
4.202	11/01/05	SLIZBEGE UNITED STATES TREAS	3.875%	9/15/06	9/15/10	615	500,000.00	\$104.641	529,490.00	492,854.95	2,474.52	495,329.47	44,482.88	573,972.88				
TOTAL										500,000.00	\$	529,490.00	\$	492,854.95	\$	495,329.47	\$	573,972.88
MONEY MARKET FUNDS																		
4.460		PRIME FUND - CAPITAL RESERVES	4.460%		n/a	n/a	4,948,289.18	\$1,000	4,948,289.18	\$4,948,289.18	\$0.00	\$4,948,289.18	\$	\$29,020,832.13				
TOTAL ACCOUNT										10,165.46	\$	3,314.07	\$	3,314.07	\$	3,314.07	\$	3,314.07
TOTAL ACCOUNT										\$6,722,944.64	\$	\$3,273.05	\$	\$6,682,854.75	\$	\$24,117,824.35	\$	\$30,833,917.60

Account # K4K 065919

Purchase Date	Symbol/USIP	Security Description	CPN	Last CPN	Maturity Date	Days to Maturity	Closing Quantity	Recent Price	Recent Market Value	Bond	Coef Interest	Total	Unpaid Interest (UPI)	Market Value and UPI				
4.775	03/15/06	46625HDD9 JP MORGAN	4.600%	7/17/06	1/17/11	737	1,500,000.00	\$97.140	1,473,465.00	1,488,679.95	19,933.33	1,508,613.28	172,116.67	1,645,561.67				
MONEY MARKET FUNDS																		
4.460		PRIME FUND - CAPITAL RESERVES	4.460%	10/31/06	n/a	n/a	133,323.71	\$1,000	133,323.71	133,323.71	0.00	133,323.71	12,902.52	146,226.23				
TOTAL ACCOUNT										1,633,323.71	\$	19,933.33	\$	1,661,870.32	\$	185,019.19	\$	1,811,741.23
TOTAL PORTFOLIO										\$8,361,166.68	\$	\$23,206.38	\$	\$8,344,725.07	\$	\$24,302,843.54	\$	\$32,645,658.93

Water Replenishment District



MEMORANDUM

ITEM NO. 5.G

Prepared by: Abbie Andom

Reviewed by: Scott M. Ota

Approved by: Robb Whitaker

DATE: MARCH 20, 2009

TO: BOARD OF DIRECTORS

FROM: ROBB WHITAKER, GENERAL MANAGER

**SUBJECT: CONSIDERATION OF RESOLUTION NO. 09- 847 –
A JOINT RESOLUTION OF THE BOARD OF SUPERVISORS OF THE COUNTY OF LOS ANGELES; THE BOARD OF DIRECTORS OF THE GREATER LOS ANGELES COUNTY VECTOR CONTROL DISTRICT; THE BOARD OF DIRECTORS OF THE COUNTY SANITATION DISTRICT NO. 8 OF LOS ANGELES COUNTY (COUNTY SANITATION DISTRICT NO. 8); THE CITY COUNCIL OF THE CITY OF CARSON; AND THE BOARD OF DIRECTORS OF THE WATER REPLENISHMENT DISTRICT OF SOUTHERN CALIFORNIA APPROVING AND ACCEPTING THE NEGOTIATED EXCHANGE OF PROPERTY TAX REVENUES RESULTING FROM ANNEXATION OF L 093-2008 TO COUNTY LIGHTING MAINTENANCE DISTRICT 1697**

SUMMARY

A request has been received from the County of Los Angeles Department of Public Works regarding participation in the exchange of ad valorem property tax. If a taxing agency involved in the negotiation does not adopt a resolution providing for the exchange of property tax, the Board of Supervisors can determine the exchange of property tax revenue for that taxing agency.

FISCAL IMPACT

None.

FINANCE COMMITTEE RECOMMENDATION

Adopt Resolution No. 09-847.

RESOLUTION NO. 09- 847

A JOINT RESOLUTION OF THE BOARD OF SUPERVISORS OF THE COUNTY OF LOS ANGELES; THE BOARD OF DIRECTORS OF THE GREATER LOS ANGELES COUNTY VECTOR CONTROL DISTRICT; THE BOARD OF DIRECTORS OF THE COUNTY SANITATION DISTRICT NO. 8 OF LOS ANGELES COUNTY (COUNTY SANITATION DISTRICT NO. 8); THE CITY COUNCIL OF THE CITY OF CARSON; AND THE BOARD OF DIRECTORS OF THE WATER REPLENISHMENT DISTRICT OF SOUTHERN CALIFORNIA APPROVING AND ACCEPTING THE NEGOTIATED EXCHANGE OF PROPERTY TAX REVENUES RESULTING FROM ANNEXATION OF L 093-2008 TO COUNTY LIGHTING MAINTENANCE DISTRICT 1697

WHEREAS, pursuant to Section 99.01 of the Revenue and Taxation Code, prior to the effective date of any jurisdictional change that will result in a special district providing one or more services to an area where those services have not previously been provided by any local agency, the special district and each local agency that receives an apportionment of property tax revenue from the area must negotiate an exchange of property tax increment generated in the area subject to the jurisdictional change and attributable to those local agencies; and

WHEREAS, the Board of Supervisors of the County of Los Angeles, acting on behalf of the County Lighting Maintenance District 1697, the Los Angeles County General Fund, the Los Angeles County Library, the Consolidated Fire Protection District of Los Angeles County, the Los Angeles County Flood Control Drainage Improvement Maintenance District, and the Los Angeles County Flood Control District; the Board of Directors of the Greater Los Angeles County Vector Control District; the Board of Directors of the County Sanitation District No.8 of Los Angeles County (County Sanitation District No. 8), the City Council of the City of Carson; and the Board of Directors of the Water Replenishment District of Southern California have determined that the amount of property tax revenue to be exchanged between their respective agencies as a result of the annexation proposal identified as L 093-2008 into County Lighting Maintenance District 1697 is as shown on the attached Property Tax Transfer Resolution Worksheet.

NOW, THEREFORE, BE IT RESOLVED AS FOLLOWS:

1. The negotiated exchange of property tax revenues between the County Lighting Maintenance District 1697, and the Los Angeles County General Fund, the Los Angeles County Library, the Consolidated Fire Protection District of Los Angeles County, the Los Angeles County Flood Control Drainage Improvement Maintenance District, the Los Angeles County Flood Control District, the Greater Los Angeles County Vector Control District, the County Sanitation District No.8, the City of Carson, and the Water Replenishment District of Southern California resulting from the annexation proposal identified as L 093-2008 to County Lighting Maintenance District 1697 is approved and accepted.

2. For annexation projects within a City of Carson Community Redevelopment Project Area (RPA), County Lighting Maintenance District 1697 will not receive the negotiated share of annual tax increment (ATI) until such time as the affected RPA is terminated for purposes of receiving ATI.
3. For fiscal years commencing on or after July 1, 2008, or the July 1 after the effective date of this jurisdictional change, whichever is later, the property tax revenue increment generated from the area within L 093-2008 (Tax Rate Area 05483) shall be allocated to the affected agencies as indicated in the enclosed Property Tax Transfer Resolution Worksheet.
4. No transfer of property tax revenues other than those specified in Paragraph 3 shall be made as a result of annexation of L 093-2008.
5. If at any time after the effective date of this Resolution, the calculations used herein to determine initial property tax transfers or the data used to perform those calculations are found to be incorrect, thus producing an improper or inaccurate property tax transfer, the property tax transfer shall be recalculated and the corrected transfer shall be implemented for the next fiscal year, and any amounts of property tax received in excess of that which is proper shall be refunded to the appropriate agency.

PASSED, APPROVED AND ADOPTED THIS 20th day of March, 2009 by the following vote:

AYES:
NOES:
ABSENT:
ABSTAIN:

WATER REPLENISHMENT DISTRICT OF SOUTHERN CALIFORNIA

Albert Robles, President

ATTEST:

Lillian Kawasaki, Secretary

Date



MEMORANDUM

ITEM NO. 6

<i>Prepared by:</i>	Ted Johnson
<i>Reviewed by:</i>	Robb Whitaker
<i>Approved by:</i>	Robb Whitaker

DATE: MARCH 20, 2009

TO: WATER RESOURCES COMMITTEE

FROM: ROBB WHITAKER, GENERAL MANAGER

**SUBJECT: CONSIDERATION OF RESOLUTION NO. 09-848 -
A RESOLUTION OF THE BOARD OF DIRECTORS OF THE WATER REPLENISHMENT DISTRICT OF SOUTHERN CALIFORNIA ORDERING ACCEPTANCE AND FILING OF THE ENGINEERING SURVEY AND REPORT SUBMITTED PURSUANT TO SECTION 60300 OF THE WATER CODE, DECLARING THAT FUNDS SHALL BE RAISED FOR THE PURCHASE OF WATER FOR REPLENISHMENT AND FOR GROUNDWATER REPLENISHMENT AND QUALITY PROGRAMS AND PROJECTS DURING THE ENSUING FISCAL YEAR, THAT SUCH FUNDS SHALL BE RAISED BY A REPLENISHMENT ASSESSMENT AS PROVIDED IN SAID WATER CODE, DECLARING THAT THE FUNDS TO BE RAISED BY SAID REPLENISHMENT ASSESSMENT WILL BENEFIT, EITHER DIRECTLY OR INDIRECTLY, ALL OF THE PERSONS, REAL PROPERTY AND IMPROVEMENTS WITHIN THE DISTRICT, AND ORDERING THE PUBLICATION OF A NOTICE OF PUBLIC HEARING IN ACCORDANCE WITH SECTION 60306 OF THE WATER CODE**

SUMMARY

On January 16, 2009, the Board of Directors adopted Resolution No. 09-846 ordering the preparation of the annual Engineering Survey and Report (ESR). This report determines, among other things, the condition of the groundwater basins and the replenishment water needs and costs for the ensuing year. This information, combined with the ongoing budgeting process, will provide the Board with the necessary information to determine the Replenishment Assessment (RA) for the ensuing year 2009/2010, currently scheduled for May 1, 2009.

Staff is pleased to have completed the 2009 ESR, especially in light of the District celebrating its 50th year anniversary. The District has accomplished so much over the past 50 years, including adding over 5-1/2 million acre feet of water to the groundwater basins, halting seawater intrusion, cleaning up contamination, building an extensive groundwater monitoring network, educating the public and other stakeholders on the importance of groundwater supply and protection, and many other accomplishments that have helped protect and sustain the groundwater resource.

The full ESR can be found on the District's Web Site at <http://www.wrd.org> or can be obtained by contacting this office. A summary of the ESR findings is presented below:

- Total groundwater production in 2007/08 was 244,732 acre feet. In the current year 2008/09 it is estimated that production will equal 240,000 acre feet. For the ensuing year, it is estimated that total production will equal 240,200 acre feet.
- There will be an annual overdraft in the ensuing year estimated at 94,800 acre feet. In 2007/08 a total of 41,600 acre feet were removed from storage since pumping exceeded inflows to the basins. The accumulated overdraft at the end of 2007/08 was determined to be 701,800 acre feet. The basins are 89,800 acre feet below the optimum quantity of an accumulated overdraft of 612,000 acre feet.
- The District plans to purchase 106,703 acre feet of replenishment water in the ensuing year. It is uncertain if spreading and in-lieu water will be available in the ensuing year due to drought and Bay-Delta issues, but any collected and unused monies would roll over into subsequent year purchases as make-up replenishment. The cost for this replenishment water is estimated at \$27,628,844. This is \$4.6 million more than the previous year water estimate, mostly due to the expected MWD increases in the cost of imported replenishment water. Based on WRD's success in developing alternative sources of water over the recent years and plans for future years, the full impact of these increases may be tempered. However, the rising cost of imported water accentuates the importance of the WRD Water Independence Now (WIN) Program that will eliminate the District's need for imported water to replenish the groundwater basins.
- Important projects and programs will be necessary for groundwater replenishment and groundwater quality activities to ensure the current and future reliability of the basins. These project and programs are outlined in the ESR.

Upon the Board's receipt and filing of the ESR, it must declare by Resolution whether funds will be raised to purchase water for replenishment for the ensuing fiscal year and how those funds will be raised. The Resolution must also declare whether funds will be raised to remove contaminants from groundwater supplies during the ensuing fiscal year or to exercise any other power under Section 60224 of the Water Code. Attached is Resolution No. 09-848 for the Board to consider adoption.

FISCAL IMPACT

None at this time.

WATER RESOURCES COMMITTEE RECOMMENDATION

Receive and file the 2009 Engineering Survey and Report and adopt Resolution No. 09-848.

RESOLUTION NO. 09-848

A RESOLUTION OF THE BOARD OF DIRECTORS OF THE WATER REPLENISHMENT DISTRICT OF SOUTHERN CALIFORNIA ORDERING ACCEPTANCE AND FILING OF THE ENGINEERING SURVEY AND REPORT SUBMITTED PURSUANT TO SECTIONS 60300 AND 60301 OF THE WATER CODE, DECLARING THAT FUNDS SHALL BE RAISED FOR THE PURCHASE OF WATER FOR REPLENISHMENT AND FOR GROUNDWATER REPLENISHMENT AND QUALITY PROGRAMS AND PROJECTS DURING THE ENSUING FISCAL YEAR, THAT SUCH FUNDS SHALL BE RAISED BY A REPLENISHMENT ASSESSMENT AS PROVIDED IN SAID WATER CODE, DECLARING THAT THE FUNDS TO BE RAISED BY SAID REPLENISHMENT ASSESSMENT WILL BENEFIT, EITHER DIRECTLY OR INDIRECTLY, ALL OF THE PERSONS, REAL PROPERTY AND/OR IMPROVEMENTS WITHIN THE DISTRICT, AND ORDERING THE PUBLICATION OF A NOTICE OF PUBLIC HEARING IN ACCORDANCE WITH SECTION 60306 OF THE WATER CODE

WHEREAS, there has been submitted to the Secretary of the Board of the Water Replenishment District of Southern California ("District") the engineering survey and report heretofore ordered pursuant to Sections 60300 and 60301 of the California Water Code; and

WHEREAS, the Board of Directors of the District ("Board") has received said report;

NOW, THEREFORE, BE IT RESOLVED AND DECLARED BY THE BOARD OF THE WATER REPLENISHMENT DISTRICT OF SOUTHERN CALIFORNIA:

Section 1. That the said engineering survey and report be received and filed in the records of the District;

Section 2. That funds shall be raised to purchase water for replenishment of the groundwater supplies within the District during the next ensuing fiscal year of the District, Fiscal Year 2009-2010, and to accomplish all acts reasonably necessary to said replenishment, including but not limited to the development and operation of capital projects, and that such funds shall be raised by a replenishment assessment, as provided in California Water Code Sections 60300 et seq;

Section 3. That funds shall be raised to remove contaminants from groundwater supplies and to exercise any other power under California Water Code Section 60224, including but not limited to developing and operating capital projects, and that such funds shall be raised by a replenishment assessment as provided by California Water Code Section 60300 et seq;

Section 4. That funds shall be raised to pay for the District's operating and administrative expenses and such funds shall be raised by a replenishment assessment pursuant to California Water Code Section 60300 et seq;

Section 5. A public hearing shall be held on or before the second Tuesday in April, 2009 or as otherwise specified under the California Water Code Section 60043 for the purpose of determining whether and to what extent the estimated cost of the actions described in Sections 2, 3, and 4, above for the ensuing fiscal year shall be paid for by a replenishment assessment;

Section 6. That the funds so raised to accomplish the actions described in Sections 2, 3 and 4, above during the next ensuing fiscal year, 2009-2010, will benefit, directly or indirectly, all of the persons and/or real property and improvements within the District;

Section 7. That the General Manager of the District shall cause to be published on behalf of the Board a notice that a public hearing will be held for the purposes described in Section 5, above. Such notice shall be published once in the Los Angeles Bulletin, an adjudicated paper of general circulation in Los Angeles County, at least ten (10) days before said hearing. Such notice shall contain a copy of said Board's resolution, the time and place of said hearing, and an invitation to all interested parties to attend and be heard in support of or in opposition to said proposed assessment, and shall invite inspection of the engineering survey and report upon which the Board acted.

PASSED, APPROVED AND ADOPTED this 20th day of March, 2009.

Albert Robles, Board President

ATTEST:

Lillian Kawasaki, Board Secretary



MEMORANDUM

ITEM NO. 7

Prepared by: Hoover Ng

Reviewed by: Ted Johnson

Approved by: Robb Whitaker

DATE: MARCH 20, 2009

TO: BOARD OF DIRECTORS

FROM: ROBB WHITAKER, GENERAL MANAGER

SUBJECT: STATE WATER RECYCLING POLICY ADOPTION - REPORT

SUMMARY

On February 3, 2009, the State Water Resources Control Board (SWRCB) adopted a new water recycling policy. This policy was the culmination of an unprecedented and major effort involving key stakeholder groups, including WRD who had prepared and provided to the Board a draft policy which was slightly modified and became the adopted policy.

Key elements and highlights of this policy include following:

General

1. Establishes mandates (or goals) for recycled water use statewide. This is intended to encourage water recycling throughout the state.
2. Recognizes distinct roles of the SWRCB, Regional Boards, and the California Department of Public Health (CDPH). Of particular importance is that the Regional Boards shall defer to the CDPH to prescribe requirements to protect human health.

Groundwater related

3. Requires salt/nutrient management plans to be developed for every groundwater basin/sub-basin in the state within 5 years to ensure that basin water quality objectives are not exceeded. For the Central and West Coast Basins, the District intends to have a significant role in the development of these plans.
4. For Groundwater Recharge projects, convene an expert panel to address Chemicals of Emerging Concern (CEC's), e.g. pharmaceuticals, personal care products, and endocrine disrupting compounds, and to develop recommendations for selection and monitoring for such projects.
5. For water recycling projects that use reverse osmosis prior to spreading, provide an expedited process to issue permits within one year of an application.
6. To meet requirements of the antidegradation policy, which prohibits changes in ambient groundwater quality unless there is maximum benefit to the state, an antidegradation analysis will be required to demonstrate that a project will not exceed 10 percent of the assimilative capacity of a basin. This capacity is the difference between ambient groundwater quality levels and basin water quality objectives.

Other

7. For landscape irrigation projects that meet specified criteria, provide a “streamlined approval” process to issue permits within 120 days of an application and shall exclude groundwater monitoring.
8. For incidental runoff from the use of recycled water, utilize best management practices to reduce such runoff.

Background

The origin of this new state water recycling policy occurred on April 5, 2006 when the SWRCB adopted Board Order No. 2006-001, which rescinded the use of Notification Levels as effluent limits in the Waste Discharge and Water Recycling Requirements for the Alamitos Barrier Recycled Water Project, Order No. R4-2005-0061. In the course of making this decision, the SWRCB discussed the need for reviewing existing state policies to ensure that they promoted water recycling and that permits throughout the state be consistent in their requirements, and therefore directed staff to develop a new water recycling policy.

In March 2007, the SWRCB solicited public comments for development of a revised and updated water recycling policy. The District worked closely with other interested water recycling interests and the WaterReuse Association to provide comments in support of this new endeavor. In February 2008, the SWRCB issued a draft policy and received public comments in March 2008. It became clear that there were major differences among the various stakeholders regarding this policy. As a result, key stakeholders, in an unprecedented action, joined together and requested the Board to allow them to develop their own version of a comprehensive draft water recycling policy. The SWRCB granted this group 90 days to develop their policy. The groups represented included the following:

- Association of California Water Agencies
- Heal the Bay
- California Association of Sanitation Agencies
- California Coastkeeper Alliance
- WaterReuse Association , California Section
- Planning and Conservation League
- Environmental Justice Coalition/ Southern California Watershed Alliance

The stakeholders worked in earnest and developed a near-ready draft on July 15, 2008. They requested another extension, which was granted, and submitted their draft on September 2, 2008. The SWRCB directed staff to utilize this draft as a basis for issuing another draft by the end of 2008.

The District participated throughout this process, submitted comments, provided testimony and supported the efforts of the WaterReuse Association, which represented the water recycling community. In addition, funding was provided at the request of the WaterReuse Association, the Association of California Water Agencies, and the California Association of Sanitation Agencies to help offset the extraordinary and unanticipated legal costs borne by

these associations in this effort. This collaborative effort worked well and was effective in demonstrating to the SWRCB that the stakeholders were able to work out their initial differences for the sake of promoting the increased and safe use of recycled water while being protective of the state's groundwater basins.

This item was presented to the Groundwater Quality Committee on March 6, 2009 and the Water Resources Committee on March 12, 2009.

FISCAL IMPACT

None.

STAFF RECOMMENDATION

For information.



MEMORANDUM

ITEM NO. 8

*Prepared by Charlene King
Reviewed by Robert Siemak
Approved by Robb Whitaker*

DATE: MARCH 20, 2009

TO: BOARD OF DIRECTORS

FROM: ROBB WHITAKER, GENERAL MANAGER

SUBJECT: AWARD OF PROFESSIONAL SERVICES FOR SAFE DRINKING WATER PROGRAM (SDWP)

The District administers the Safe Drinking Water Program (SDWP) to assist basin purveyors in sustaining active production from contaminated wells. Wells are evaluated for assistance based on factors such as water quality data and production history. When assistance is deemed necessary, WRD and the groundwater producer jointly develop a treatment solution for the subject well.

In 2008, the City of Vernon approached WRD for assistance to treat groundwater contamination at Vernon Wells 9 & 10. Well 9 is affected with carbon tetrachloride (CCL4), 1, 2-dichloroethane (1, 2-DCA), and trichloroethylene (TCE) above their respective current California Department of Public Health (CDPH) Maximum Contaminant Levels (MCLs). Well 10, located on the same well site, is affected with trichloroethylene (TCE). On March 21, 2008, the Board approved funding for Vernon Wells 9 & 10 through the Safe Drinking Water Program. Since that time, the City of Vernon conducted rehabilitation operations on the wells and they are ready to proceed with the installation of a treatment facility to place the wells back into service.

WRD solicited proposals using the current WRD list of pre-qualified consultants for professional technical services. The selected professional services firm will provide planning, design, construction management assistance, and inspection services for the project wells. In the Request for Proposal, candidates were instructed to include two additional projects in addition to Vernon Wells 9 & 10 for future VOC removal Safe Drinking Water Projects that may transpire this calendar year. By combining a total of three (3) projects, WRD can take advantage of economies of scale and better value than if contracted and performed separately. On February 17, 2009, four (4) proposals were received from the following firms: Carollo, Lee & Ro, Tetra Tech Inc., and URS Corporation. The proposals were reviewed, evaluated, and a selection was made by WRD staff and a representative from the City of Vernon. Evaluations were based on the understanding of the scope of work, the relevant experience of the project team, experience with projects of this nature, and the cost for the scope of work. The evaluation panel recommends URS Corporation for an amount not to exceed \$173,645 plus 15% contingency for a total amount of \$200,000.

Firm	Cost Estimate	Hours			Unit cost
	Based on 3 Projects	Design	CM	Total	\$/hr
URS Corporation	\$173,645	1578	385	1963	\$88
Lee and Ro *	\$292,416	2016	342	2358	\$124
Carollo *	\$643,917	2781	1056	3837	\$168
Tetra Tech *	\$800,806	3918	1140	5058	\$158

* Proposals received contained scope and cost estimates for one site and cost were adjusted to

reflect work at three sites for cost comparison purposes.

FISCAL IMPACT

The proposal cost for URS Corporation is \$173,645. Staff also recommends a 15% contingency on the project for a total contract amount not to exceed \$200,000. Staff is currently reviewing the 08/09 budget for the annual midyear budget review and will present funding scenarios to the Board on March 20, 2009.

GROUNDWATER QUALITY COMMITTEE RECOMMENDATION

The Groundwater Quality Committee reviewed this item on March 6, 2009. Due to a potential conflict of interest that the Committee Chair may have, the staff recommendation was deferred to the Board for their consideration.



MEMORANDUM

ITEM NO. 9

*Prepared by: Elsa Lopez
Reviewed by: Abbie Andom
Approved by: Robb Whitaker*

DATE: MARCH 20, 2009
TO: BOARD OF DIRECTORS
FROM: ROBB WHITAKER, GENERAL MANAGER
SUBJECT: WATER 101 FORUMS

SUMMARY

The proposed WRD's Water 101 Forums are briefings designed to educate the public about California's water supply and WRD. The Forums will provide information about imported and local water supplies including water quality, water reliability, environmental issues, technical issues and water economics. The WRD Water 101 Forums will feature the District's Water Independence Now (WIN) program, including the District's Groundwater Reliability Improvement Program (GRIP) and Conjunctive Use. The Forums will also highlight the District's 50th Anniversary including the accomplishments that WRD has made in decreasing our region's reliance on imported water and improving water quality.

The Water 101 Forums target audience will include the general public, policy makers, elected officials and their staff. It is anticipated to convene the Forums at four to five locations within the District each year. The cost per Forum is estimated to average \$2,500. District staff will also seek partners to minimize the cost to WRD.

The External Affairs Committee reviewed the item at its February 18, 2009 meeting and recommended Board approval of the Water 101 Forums. The Committee further requested staff to come back to the Committee with the budget and funding mechanism.

FISCAL IMPACT

Not budgeted in the '08-'09 FY External Affairs Budget. Funds will need to be allocated from other areas of the budget.

EXTERNAL AFFAIRS COMMITTEE RECOMMENDATION

Approve the Water 101 Forum program, and direct staff to develop a budget including identification of partners to assist in funding the program for review by the External Affairs Committee.



MEMORANDUM

ITEM NO. 10

Prepared by: Ellin Davtyan

Reviewed by: Scott M. Ota

Approved by: Robb Whitaker

DATE: MARCH 20, 2009

TO: BOARD OF DIRECTORS

FROM: ROBB WHITAKER, GENERAL MANAGER

SUBJECT: ADMINISTRATIVE CODE REVISIONS – AMENDMENT TO SECTION 13.2.4 OF CHAPTER 10 OF THE WRD ADMINISTRATIVE CODE RELATING TO 10% REDUCTION OF TRAVEL BUDGET AND ENCUMBRANCE OF TRAVEL BUDGETS FOR MEMBERS OF THE BOARD OF DIRECTORS

SUMMARY

The attached Resolution No. 09-XXX, if adopted, will amend provisions of Section 13.2.4, entitled "Travel Expenses" of Chapter 10 of the Administrative Code that relate to Director's Travel Budget.

Reduction of Travel Budget

The Finance Committee proposed and recommended a 10% reduction in the Director's travel allocation in the 2009/2010 budget.

The 10% budget reduction is a budgetary adjustment and does not require a change to the Administrative Code, but, if approved, the resulting 10% savings will be incorporated into the 2009/2010 budget planning process.

Encumbrance of Director's Travel Budget

The Finance Committee also proposed and recommended an annual year-end analysis of the Director's individual travel budgets resulting in an encumbrance of unused funds for use in the subsequent fiscal year. The amount of the encumbrance will be for an amount equal to the unused portion of that year's unused travel budget for each Director.

This will also be applied to the 10% contingency as provided in Section 13.2.4 of WRD Administrative Code. Currently, the pertinent requirements of Section 13.2.4 provide:

- a) The District will budget up to \$3,000 for each of the five Directors to attend annual legislative trips to Washington D.C. and Sacramento, California;
- b) The District will also budget \$7,500 for each Director to cover all other District travel;
- c) The District will also budget a 10% contingency fund;
- d) The District budget will be adjusted by the change in consumer priced index each year.

The Finance Committee recommends the encumbered funds would be carried over for one fiscal year only and the encumbered funds will be used first, prior to using the current fiscal year's Director's travel budget.

Presently, there is no provision in the Administrative Code for an encumbrance of funds related to the Director's travel budget. Thus, the Finance Committee proposed and recommended inclusion of the following subsection (e) to Section 13.2.4 to provide and read as follows:

- e) *Unspent budgeted funds from the travel budget for items listed in subsections a), b) and c) above, will be encumbered and available for use respectively in the subsequent fiscal year.*

The unspent funds related to subsection a), b) and c) are only available for use in the fiscal year immediately following the encumbrance; funds are not cumulative. The carryover of encumbered funds will be used first prior to using any of the Director's current year's travel budget.

Out of State Travel Expenses

The Finance Committee proposed and recommended the deletion of Section 13.2.4. At present, Section 13.2.4 of the Administrative Code states that the Board should pre-approve requests for out of state travel. The Finance Committee has recommended the elimination of this pre-approval requirement for the budgeted travel only, i.e., if expenditure is within the Directors budget allowance as provided in Section 13.2.4 of WRD Administrative Code pre-approval is not required. The staff has discussed this with District Counsel who has stated that there are no known state or federal laws that would require the Board's pre-approval of out of state travel requests. Thus, the attached Resolution will delete the following language from Section 13.2.4:

*The Board of Directors should pre-approve requests for out of state travel.
The Board may retroactively approve out of state travel based on difficult or unexpected circumstances.*

Election to Re-Allocate Travel Budget to Event Sponsorships and Community Grant Program During Mid-Year Budget Review

The Finance Committee also proposed and recommended that each Director be given a one-time election each year to transfer a portion of their individual unused travel budget to their individual event sponsorship and/or community grant program budget. The election would take place each year during a Board meeting for the midyear budget review process, typically held in March of each fiscal year. Once the election is made each year, it is irrevocable.

At this time, there is no provision in the Administrative Code for a reallocation of funds from the Director's travel budget to the Director's event sponsorship and/or community grant program.

Consequently, the Finance Committee proposed and recommended including subsection (f) to Section 13.2.4 to provide and read as follows:

f) Unspent budgeted funds for items listed in subsections a) and b) above, can be re-allocated to the respective individual Director's event sponsorship and/or community grant program allocation. However, the re-allocation must take place during an open session board meeting in a time coinciding with the Board's annual midyear budget review. Once the election is made to transfer excess funds from the individual Director's travel budget to the respective individual Director's event sponsorship or community grant program budget each year, the re-allocation is irrevocable. Unspent budgeted funds relating to the 10% contingency as outlined in subsection c) above are not available for reallocation.

FISCAL IMPACT

Reduction of travel budget will reduce the 2009/2010 budget by a total of \$6,325 when compared to the 2008/09 budget.

FINANCE COMMITTEE RECOMMENDATION

Adopt Resolution No. 09-XXX, amending Section 13.2.4, entitled "Travel Expenses" of Chapter 13 of the Administrative Code to include provisions relating to 1) delete the requirement that the Board pre-approve any requests for out of state travel and 2) include provisions relating to encumbrance of Director's Travel Budget.

RESOLUTION NO. 09-XXX

**RESOLUTION OF THE BOARD OF DIRECTORS
OF THE WATER REPLENISHMENT DISTRICT OF SOUTHERN CALIFORNIA
AMENDING SECTION 13.2.4 OF THE ADMINISTRATIVE CODE
RELATING ENCUMBRANCE OF TRAVEL BUDGET FOR MEMBERS OF THE
BOARD OF DIRECTORS**

WHEREAS, members of the Board of Directors (“Board”) of the Water Replenishment District of Southern California (“District”) and District employees perform official duties that require travel; and

WHEREAS, the official duties that involve travel include training, conferences, meetings with legislators and regulators, and meetings with staff and officials of surrounding communities regarding matters of mutual importance; and

WHEREAS, the performance of such official duties facilitates the efficient and satisfactory completion of District’s business and promotes a good relationship between the District and surrounding communities, the state government, and the federal government; and

WHEREAS, members of the District’s Board and District employees incur expenses related to the performance of official duties, which may take place both within and outside of the District’s boundaries; and

WHEREAS, the California Water Code and Government Code permit the District to reimburse employees and members of the Board for actual and necessary expenses incurred in the performance of official duties; and

WHEREAS, the District’s Board has adopted an resolution authorizing reimbursement for the members of the board for expenses incurred in the performance of official duties; and

WHEREAS, Assembly Bill 1234 (2005) (“AB 1234”) requires board of directors for water districts, prior to providing reimbursement to members of the District’s Board, adopt a policy regarding the reimbursement for expenses incurred by members of legislative bodies in the performance of official duties; and

WHEREAS, the District’s current policy is substantially in conformance with AB 1234, however, the District desires to revise its policy relating to travel expenses; and

WHEREAS, the proposed amendments were considered by the Finance Committee on February 23, 2009 meetings and

WHEREAS, the Finance Committee, after review and consideration, recommended the approval of this Resolution.

NOW, THEREFORE, THE BOARD OF DIRECTORS OF THE WATER REPLENISHMENT DISTRICT DOES RESOLVE AS FOLLOWS:

1. Section 13.2.4, entitled "Travel Expenses" of Chapter 13 (Expenses) of the District's Administrative Code, is hereby amended to add subsections (e) and (f), to read in its entirety as follows:

e) Unspent budgeted funds from each individual Director's travel budget for items listed in subsections a) and b) above, will be encumbered from unreserved fund balance and available for use by each individual Director in the subsequent fiscal year.

Unused monies related to the 10% contingency fund in subsection c) above, will be encumbered and added to the subsequent year's contingency fund available at the discretion of the Board President.

The unspent funds related to subsection a), b) and c) are only available for use in the fiscal year immediately following the encumbrance; funds are not cumulative. The carryover of encumbered funds will be used first prior to using any of the Director's current year's travel budget.

f) Unspent budgeted funds for items listed in subsections a) and b) above, can be re-allocated to the individual Director's event sponsorship and/or community grant program allocation. The election will take place during an open session Board meeting in a time coinciding with the Board's annual mid-year budget review. Once the election is made to transfer excess funds from the individual Director's travel budget to the individual Director's event sponsorship or community grant program budget each year, the election is irrevocable. Unspent budgeted funds relating to the 10% contingency as outlined in subsection c) above are not available for reallocation.

PASSED, APPROVED AND ADOPTED THIS ____th day of _____ 2009 by the following vote:

AYES:
NOES:
ABSENT:
ABSTAIN:

[SIGNATURE ON THE NEXT PAGE]

WATER REPLENISHMENT DISTRICT OF SOUTHERN CALIFORNIA

Albert Robles, President

ATTEST:

Lillian Kawasaki, Secretary

DATE

APPROVED AS TO FORM:

James M. Casso
District Counsel



MEMORANDUM

ITEM NO. 11

Prepared by: Elsa Lopez
Reviewed by: Abbie Andom
Approved by: Robb Whitaker

DATE: MARCH 20, 2009

TO: BOARD OF DIRECTORS

FROM: ROBB WHITAKER, GENERAL MANAGER

SUBJECT: AWARD OF CONTRACT FOR OUTREACH SERVICES FOR THE
SANITATION DISTRICTS OF LOS ANGELES COUNTY EARTH DAY EVENT

SUMMARY

The Sanitation Districts of Los Angeles County will be celebrating Earth Day 2009 on Saturday, April 18, 2009, from 10:00 a.m. to 2:00 p.m. The activity is a free community-wide event in which WRD would be participating as a co-sponsor. Earth Day 2009 will be held at the Sanitation Districts Joint Administration Office Parking Lot located at 1955 Workman Mill Road in Whittier. Earth Day seeks to promote environmental awareness and education for the whole family. The event features educational booths, interactive workshops, arts and crafts, activities for children, and entertainment such as music, an environmental magician, and more.

At the WRD Special Board Meeting of March 6, 2009, the Board discussed using automated recorded phone calls to residents within the WRD service area to increase attendance at events like the WRD Groundwater Festival and the Earth Day celebration. Chemeria Consultancy provided a proposal to President Robles to conduct such an automated recorded phone message outreach program to residents within the WRD service area. This proposal included an initial phone call and an optional follow-up phone call. The cost of this service ranged from \$10,800 to \$13,800 depending upon the size of the target area. With the follow-up phone call option, the total cost ranged from \$17,120 to \$22,954, again depending upon the size of the target area.

Because of the late notice and limited time before the WRD Groundwater Festival, the Board did not support retaining the Chemeria Consultancy but did express interest in contracting them for the Earth Day event. The Board directed staff to bring the item back to the regular meeting of March 20 for consideration by the Board.

FISCAL IMPACT

Depending on the options contracted, the service cost range is approximately \$11,000 to \$23,000. This is not a budgeted item. Funds will need to be allocated from other areas of the budget.

BOARD RECOMMENDATION

At the Special Board Meeting of March 6, 2009, the Board directed staff to bring this item to the regular meeting of March 20 for consideration by the Board.



MEMORANDUM

ITEM NO. 12

<p><i>Prepared by:</i> Abbie Andom <i>Reviewed by:</i> Scott Ota <i>Approved by:</i> Robb Whitaker</p>
--

DATE: MARCH 20, 2009
TO: BOARD OF DIRECTORS
FROM: ROBB WHITAKER, GENERAL MANAGER
SUBJECT: MIDYEAR BUDGET REVIEW

SUMMARY

Each year, staff prepares a midyear analysis of the current year's budget. The analysis will include 5 months of actual data from July 1, 2008 and November 30, 2008 along with projected data from December 31, 2008 through June 30, 2009. This information gives the Board and staff a "snapshot" of how the District is progressing with planned projects and programs. The midyear review analysis is used as a guide for the ensuing year's budget.

A presentation and additional information will be provided at the meeting.

FISCAL IMPACT

None.

FINANCE COMMITTEE RECOMMENDATION

For discussion.



MEMORANDUM

ITEM NO. 13

Prepared by: Sheryll Moffat
Reviewed by: Michael Gagan
Approved by: Robb Whitaker

DATE: MARCH 20, 2009
TO: BOARD OF DIRECTORS
FROM: ROBB WHITAKER, GENERAL MANAGER
SUBJECT: WRD HISTORY REPORT

SUMMARY

On November 17, 1959, voters in the region approved the formation of the Central and West Basin Water Replenishment District. Under the auspices of the Ad Hoc History Committee, each Board meeting will include an essay by Michael Gagan on significant aspects of the District's pre-formation years.

This month's topic: The decision to form a replenishment district concluded a process that began with the formation of the West Basin Survey Committee in 1942. Changing water conditions underground combined with legal and institutional developments to make the decision 16 years later to form a replenishment district virtually inevitable.

FISCAL IMPACT

Not applicable.

STAFF RECOMMENDATION

For information.

March 2009

Sequence of Events Leading to Water Replenishment District Formation

The benchmark Walter Mendenhall studies on the Development of Underground Waters in the Central and Western Coastal Plains documented the production of groundwater in excess of natural replenishment in the early 1900s. Published by the U.S.G.S in 1905, the studies noted the “accelerating development” that had occurred in the area over the previous four decades. Increased stream diversion by constructed ditches and canals reduced the volume of natural replenishment, as did the increased runoff to the ocean caused by housing, businesses and roads. Mendenhall characterized these as “two disturbing elements” that were “destroying” the natural balance between water supply and water demand. As a result, formerly large swaths of Artesian land were shrinking and depth to groundwater was increasing.

The widespread introduction of the electric pump to replace windmills and steam generators made it possible to pump more water more quickly and from deeper sources as demand for groundwater continued to grow along with the population in the first decades of the 20th century. Groundwater extractions spiked upward with the new industrial demand that resulted from oil drilling in the Signal Hill and Long Beach areas in the 1920s and the Wilmington oil fields in the 1930s. Pre-War preparedness and the jobs resulting from it, including a rapidly growing military mobilization, increased both industrial and domestic demand for water in an area that in 1940 was still the agricultural capital of California. The population in what is now WRD’s service area grew from 590,000 in 1930 to 1,017,000 in 1940.

By 1940, groundwater extractions greatly exceeded natural replenishment. Pumpers in both basins were drawing water at ever-increasing depths and seawater intrusion was well underway in West Basin and was in the early stages of migration in Central Basin. Adverse conditions were more acute and pronounced in West Basin than in Central Basin and for that reason, the series of institutional steps that led to the ultimate formation of the Water Replenishment District began on the West Basin side.

As Elinor Ostrom put it in her 1990 study (Governing the Commons: The Evolution of Institutions for Collective Action), the process of institutional development in both basins was “incremental and sequential,” one step leading to another in a more or less orderly way. While developments in the respective basins occurred at a different pace, both basins ended in the same place with a common replenishment district and, shortly

after that, with final court judgments limiting groundwater extractions and fixing the rights of those parties lawfully empowered to pump.

Organizationally, what ended in 1959 with voter approval of the Central and West Basin Water Replenishment District began in 1942 with formation of the West Basin Water Survey Committee. Viewed chronologically, one step in the institutional development process led logically to the next, with each succeeding step informed by the experience of what went before. Pumpers organized voluntarily to gather and share information. On the West Basin side, they sought court action to curtail groundwater production and establish water rights. The West Basin court experience informed what eventually happened in Central Basin. Pumpers sought and successfully obtained formation of municipal water districts to bring an imported supply to the two basins. As events unfolded, it became clear that neither court action nor the introduction of imported water would protect the basins from permanent depletion and seawater intrusion or enable pumpers in either basin to pump beyond their natural safe yields. To restore and protect the groundwater basins for perpetual beneficial use, formation of a replenishment district was a logical final step.

A timeline of developments illustrates the incremental and sequential nature of the replenishment district formation. Each of the events has its own history, with its own textured story lines and larger-than-life cast of participants. Viewed chronologically, they demonstrate the deliberative and purposeful process followed over nearly two decades to form the Water Replenishment District.

West Basin Water Survey Committee Is Formed

August 1942



Judgment Entered in Pasadena v. Alhambra, et al (Raymond Basin Case)

December 23, 1944



West Basin Ground-Water Conservation Group Succeeds West Basin Water Survey Committee

January 194



**West Basin Ground-Water Conservation Group Adopts
Ways and Means Committee Report**

September 13, 1945



**Petition for Adjudication of West Basin Is Filed (California Water Service Co., et al v.
City of Compton et al)**

October 24, 1945



West Basin Water Association Is Formed

February 1946



**West Basin Water Association Publishes "An Imported Water Supply for West
Basin" by Harold Conkling**

July 15, 1946



Voters Approve Formation of the West Basin Municipal Water District

November 26, 1947



**Voters Approve Annexation of the West Basin Municipal Water District to the
Metropolitan Water District**

June 8, 1948



**Central Basin Water Survey Committee Is Formed
Ways and Means Committee Is Appointed**

June 1949



Central Basin Water Association Is Formed

June 1950



**Conservation Zone Legislation Is Adopted
Legislature Appropriates Money to Build the Experimental West Coast Basin Barrier**
1951



State Water Resources Board Publishes "Central Basin Investigation"
March 1952



**"Report of Referee" in Connection with the West Basin Adjudication Is Filed with
the Court**
September 15, 1952



Voters Approve Formation of the Central Basin Municipal Water District
December 2, 1952



**Voters Approve Annexation of the Central Basin Municipal Water District to the
Metropolitan Water District**
September 21, 1954



**Court Approves West Basin Adjudication Interim Agreement
Division of Water Resources Is Appointed Watermaster**
February 16, 1955



**Water Replenishment District Act Is Enacted
Water Extractions and Diversions Recordation Act Is Enacted**
1955



Central Basin Water Association Forms Replenishment District Committee
July 15, 1955



West Basin Water Association Forms Replenishment District Committee
August 25, 1955



Whittier Narrows Dam Is Dedicated
November 12, 1955



**West Basin Water Association Supports a Single Replenishment District Covering
Both Basins**
February 28, 1957



**Metropolitan Water District Board Adopts Statement of Policy on Water
Replenishment District**
April 16, 1957



**Central Basin Water Association Supports a Single Replenishment District Covering
Both Basins**
May 2, 1957



**Joint Executive Committees of the Two Associations Approve Proposal to Form the
Central and West Basin Water Replenishment District**

August 7, 1958



**Complaint Is Filed by the Cities of Long Beach and Compton and the Central Basin
Municipal Water District (Long Beach Judgment)**

May 12, 1959



Voter Petition Is Filed to Form the Replenishment District

May 25, 1959



Department of Water Resources Conducts Formation Hearing

July 6, 1959



**Department of Water Resources Issues "Report on Proposed Central and West Basin
Water Replenishment District"**

July 17, 1959



**Voters Approve Formation of the Central and West Basin Water Replenishment
District**

November 17, 1959