

**MEETING OF THE FINANCE COMMITTEE
OF THE BOARD OF DIRECTORS
WATER REPLENISHMENT DISTRICT OF SOUTHERN CALIFORNIA
4040 PARAMOUNT BOULEVARD, LAKEWOOD, CALIFORNIA 90712
12:00 P.M., MONDAY, OCTOBER 27, 2008**

AGENDA

EACH ITEM ON THE AGENDA, NO MATTER HOW DESCRIBED, SHALL BE DEEMED TO INCLUDE ANY APPROPRIATE MOTION, WHETHER TO ADOPT A MINUTE MOTION, RESOLUTION, PAYMENT OF ANY BILL, APPROVAL OF ANY MATTER OR ACTION, OR ANY OTHER ACTION. ITEMS LISTED AS "FOR INFORMATION" MAY ALSO BE THE SUBJECT OF AN "ACTION" TAKEN BY THE BOARD OR A COMMITTEE AT THE SAME MEETING.

- 1. DETERMINATION OF A QUORUM**
- 2. PUBLIC COMMENT**
- 3. DEBT FINANCING UPDATE**
Staff Recommendation: For discussion.
- 4. MINUTES OF THE SPECIAL MEETINGS OF SEPTEMBER 9, 2008, SEPTEMBER 25, 2008, AND OCTOBER 7, 2008**
Staff Recommendation: Approve as submitted.
- 5. DEMANDS**
Staff Recommendation: Receive and file the Demands for September 30, 2008.
- 6. FINANCIAL STATEMENTS – JULY 31, 2008**
Staff Recommendation: Approve the Financial Statements for July 31, 2008.
- 7. INVESTMENT REPORT FOR THE PERIOD ENDING JULY 31, 2008**
Staff Recommendation: Approve the Investment Report for the period ending July 31, 2008.
- 8. CONSIDERATION OF RESOLUTION NO. 08- 821– A JOINT RESOLUTION OF THE BOARD OF SUPERVISORS OF THE COUNTY OF LOS ANGELES ACTING IN BEHALF OF LOS ANGELES COUNTY GENERAL FUND, LOS ANGELES COUNTY FLOOD CONTROL, THE BOARD OF DIRECTORS OF COUNTY SANITATION DISTRICT NO. 5 OF LOS ANGELES COUNTY, AND THE GOVERNING BODIES OF LOS ANGELES COUNTY WEST VECTOR CONTROL DISTRICT, CITY OF EL SEGUNDO, AND THE WATER REPLENISHMENT DISTRICT OF SOUTHERN CALIFORNIA APPROVING AND ACCEPTING NEGOTIATED EXCHANGE OF PROPERTY TAX REVENUES**

RESULTING FROM ANNEXATION TO COUNTY SANITATION DISTRICT NO. 5 – ANNEXATION NO. 55

Staff Recommendation: Adopt Resolution No. 08-821.

- 9. CONSIDERATION OF RESOLUTION NO. 08- 837 –
A JOINT RESOLUTION OF THE BOARD OF SUPERVISORS OF THE COUNTY OF LOS ANGELES; THE BOARD OF DIRECTORS OF THE GREATER LOS ANGELES COUNTY VECTOR CONTROL DISTRICT; THE BOARD OF DIRECTORS OF THE COUNTY SANITATION DISTRICT NO. 8 OF LOS ANGELES COUNTY (COUNTY SANITATION DISTRICT NO. 8); THE CITY COUNCIL OF THE CITY OF CARSON; AND THE BOARD OF DIRECTORS OF THE WATER REPLENISHMENT DISTRICT OF SOUTHERN CALIFORNIA APPROVING AND ACCEPTING THE NEGOTIATED EXCHANGE OF PROPERTY TAX REVENUES RESULTING FROM ANNEXATION OF I 035-2008 INTO COUNTY LIGHTING MAINTENANCE DISTRICT 1697**

Staff Recommendation: Adopt Resolution No. 08-837.

10. DIRECTORS EXPENSES

Staff Recommendation: Approve Directors Expenses for submittal to the Board of Directors.

11. DIRECTORS REPORTS, INQUIRIES, AND DIRECTIONS TO STAFF

12. ADJOURNMENT

Posted by Abigail C. Andom, Deputy Secretary, October 23, 2008.

In compliance with the Americans with Disabilities Act (ADA), if special assistance is needed to participate in the Board meeting, please contact Deputy Secretary Abigail Andom at (562) 921-5521 for assistance to enable the District to make reasonable accommodations.

All public records relating to an agenda item on this agenda are available for public inspection at the time the record is distributed to all, or a majority of all, members of the Board. Such records shall be available at the District office located at 4040 Paramount Boulevard, Lakewood, California 90712.

Agendas and minutes are available at the District's website, www.wrd.org.



MEMORANDUM

ITEM NO. 3

*Prepared by: Scott M. Ota
Reviewed by: Scott M. Ota
Approved by: Robb Whitaker*

DATE: OCTOBER 27, 2008
TO: FINANCE COMMITTEE
FROM: ROBB WHITAKER, GENERAL MANAGER
SUBJECT: DEBT FINANCING UPDATE

SUMMARY

Staff will give an update to the Committee on the debt financing process.

FISCAL IMPACT

None.

STAFF RECOMMENDATION

For information.

UNAPPROVED
MINUTES

UNAPPROVED
MINUTES

**MINUTES OF SEPTEMBER 9, 2008
SPECIAL MEETING OF THE FINANCE COMMITTEE
OF THE BOARD OF DIRECTORS
WATER REPLENISHMENT DISTRICT OF SOUTHERN CALIFORNIA**

A special meeting of the Finance Committee of the Board of Directors of the Water Replenishment District of Southern California was held on July 28, 2008 at 12:30 p.m. at the District office, 4040 Paramount Boulevard, Lakewood, California. Director Sergio Calderon called the meeting to order and presided thereover. Deputy Secretary Abigail C. Andom recorded the minutes.

1. DETERMINATION OF A QUORUM

Directors: Sergio Calderon, Lillian Kawasaki
Staff: Scott Ota, Jenna Shaunessy

2. PUBLIC COMMENT

None.

3. DEBT FINANCING UPDATE

Scott Henry of De La Rosa and Associates, the District's bond underwriter, provided the Committee with a brief background of the bond issuance process and the proposed timeline for the District's second bond issuance.

Jeffrey Stava of Nossaman, Gunther, Knox, the District's bond counsel, stated that the Board adopted a resolution in 2006 declaring its intent to reimburse itself certain expenditures from proceeds of the debt issuance and it is counsel's responsibility to make sure that the proceeds are properly spent and within the three-year limitation. Mr. Stava also explained that since the District has private water companies as pumpers, counsel makes sure that the projects for reimbursement are deemed to benefit not just private water companies to avail of the tax exempt status.

Harriet Welch, disclosure counsel from Nossaman, Gunther, Knox, stated that the bond documents are almost in their final form and should be forwarded to District Counsel Jamie Casso of Meyers Nave for their review as soon as possible.

Discussion followed. The Committee asked that the bond documents be presented to the Committee at its September 22 meeting.

4. MINUTES OF THE SPECIAL MEETINGS OF JULY 11, 2008, AUGUST 15, 2008 AND AUGUST 27, 2008

The minutes were approved as submitted.

5. DEMANDS

The Committee reviewed the list of Demands for July 31, 2008. The Demands were approved for submittal to the Board of Directors to receive and file.

6. CONSIDERATION OF RESOLUTION NO. 08- 832 –

A JOINT RESOLUTION OF THE BOARD OF SUPERVISORS OF THE COUNTY OF LOS ANGELES; THE BOARD OF DIRECTORS OF THE LOS ANGELES COUNTY WEST VECTOR CONTROL DISTRICT; THE BOARD OF DIRECTORS OF THE COUNTY SANITATION DISTRICT NO. 5 OF LOS ANGELES COUNTY (COUNTY SANITATION DISTRICT NO. 5); THE CITY COUNCIL OF THE CITY OF LAWDALE; AND THE BOARD OF DIRECTORS OF THE WATER REPLENISHMENT DISTRICT OF SOUTHERN CALIFORNIA APPROVING AND ACCEPTING THE NEGOTIATED EXCHANGE OF PROPERTY TAX REVENUES RESULTING FROM ANNEXATION OF PETITION NO. 60-505 INTO LAWDALE LIGHTING DISTRICT

The Committee recommended the Board adopt Resolution No. 08-832.

7. CONSIDERATION OF RESOLUTION NO. 08- 833 –

A JOINT RESOLUTION OF THE BOARD OF SUPERVISORS OF THE COUNTY OF LOS ANGELES; THE BOARD OF DIRECTORS OF THE GREATER LOS ANGELES COUNTY VECTOR CONTROL DISTRICT; THE BOARD OF DIRECTORS OF THE COUNTY SANITATION DISTRICT NO. 8 OF LOS ANGELES COUNTY (COUNTY SANITATION DISTRICT NO. 8); THE CITY COUNCIL OF THE CITY OF CARSON; AND THE BOARD OF DIRECTORS OF THE WATER REPLENISHMENT DISTRICT OF SOUTHERN CALIFORNIA APPROVING AND ACCEPTING THE NEGOTIATED EXCHANGE OF PROPERTY TAX REVENUES RESULTING FROM ANNEXATION OF PARCEL MAP NO. 70478 TO COUNTY LIGHTING MAINTENANCE DISTRICT 1697

The Committee recommended the Board adopt Resolution No. 08-833.

8. COMMUNITY BANKING

Chief Financial Officer Scott Ota stated that staff is in the process of interviewing the four community banks the Board had identified that the District would use for its banking requirements. The four banks are: Broadway Federal Bank, One United Bank, East West Bank, and Promerica Bank.

Director Kawasaki clarified that it was not the Board's intent to utilize the four identified banks for all of WRD's banking needs and thereby transfer all of the District's existing accounts to these banks. She explained that the four banks would be utilized only for the District's day-to-day operational needs and that the District's investment accounts would be kept where they are until the investment advisor is able to make a recommendation as to where and what accounts they should go.

Director Kawasaki recommended that a tiered approach be used at the present and suggested that staff open preliminary accounts with the four banks with an initial deposit of \$100,000 per institution until due diligence is completed.

Discussion followed. The Committee recommended that staff provide an update at the next meeting on the proposed timeline for completion of due diligence efforts.

9. CPI ADJUSTMENT FOR COMMUNICATION ALLOWANCE

This item will be continued to the next meeting.

10. CPI ADJUSTMENT FOR VEHICLE ALLOWANCE

This item will be continued to the next meeting.

11. CPI ADJUSTMENT FOR DEFERRED COMPENSATION

Discussion followed and the Committee recommended the Board approve an annual increase to the deferred compensation match based on the annual CPI adjustment, applied retroactively to January 2008. The Committee further recommended that the benefit would be subject to meet and confer with the employees' bargaining group and would sunset on June 2012, when the employees' MOU next expires.

12. EXPENSES OVER 90 DAYS

The Committee reviewed expense reimbursements submitted over 90 days of the date the expense was incurred. The Committee recommended they be approved by the Board of Directors.

13. DIRECTORS EXPENSES

Director's expenses were reviewed and the Committee recommended the item be submitted to the Board for approval.

14. DIRECTORS REPORTS, INQUIRIES, AND REVIEW OF DIRECTIONS TO STAFF

Director Kawasaki stated that the quarterly budget review can be agendaized for the November Finance Committee meeting.

15. ADJOURNMENT

With no further business for the Committee, the meeting was adjourned at 2:30 p.m.

Chairperson

ATTEST:

Director

UNAPPROVED
MINUTES

UNAPPROVED
MINUTES

**MINUTES OF SEPTEMBER 25, 2008
SPECIAL MEETING OF THE FINANCE COMMITTEE
OF THE BOARD OF DIRECTORS
WATER REPLENISHMENT DISTRICT OF SOUTHERN CALIFORNIA**

A special meeting of the Finance Committee of the Board of Directors of the Water Replenishment District of Southern California was held on September 25, 2008 at 11:35 a.m. at the District office, 4040 Paramount Boulevard, Lakewood, California. Director Sergio Calderon called the meeting to order and presided thereover. Deputy Secretary Abigail C. Andom recorded the minutes.

1. DETERMINATION OF A QUORUM

Directors: Sergio Calderon, Albert Robles (alternate)
Staff: Scott Ota, Jenna Shaunessy

2. PUBLIC COMMENT

None.

3. DEBT FINANCING UPDATE

Chief Financial Officer Scott Ota informed the Committee that staff met with the bond financing team last Tuesday, September 23 and everything is on target with the final documents in its final stages of preparation. Mr. Ota stated that the bond documents are expected to be presented to the Board on October 17.

4. MINUTES OF THE MEETING OF JULY 28, 2008

The minutes were approved as submitted.

5. DEMANDS

The Committee reviewed the list of Demands for August 31, 2008. The Demands were approved for submittal to the Board of Directors to receive and file.

6. FINANCIAL STATEMENTS – JUNE 30, 2008

The Committee reviewed the Financial Statements for June 30, 2008 and recommended they be submitted to the Board for approval.

7. INVESTMENT REPORT FOR THE PERIOD ENDING JUNE 30, 2008

The Committee reviewed the Investment Report for June 30, 2008 and recommended they be submitted to the Board for approval.

**8. CONSIDERATION OF RESOLUTION NO. 08- 834– A JOINT
RESOLUTION OF THE BOARD OF SUPERVISORS OF THE COUNTY OF
LOS ANGELES ACTING IN BEHALF OF LOS ANGELES COUNTY
GENERAL FUND, LOS ANGELES COUNTY FLOOD CONTROL, THE
BOARD OF DIRECTORS OF COUNTY SANITATION DISTRICT NO. 3 OF**

LOS ANGELES COUNTY, AND THE GOVERNING BODIES OF GREATER LOS ANGELES COUNTY VECTOR CONTROL DISTRICT, CITY OF LONG BEACH, AND THE WATER REPLENISHMENT DISTRICT OF SOUTHERN CALIFORNIA APPROVING AND ACCEPTING NEGOTIATED EXCHANGE OF PROPERTY TAX REVENUES RESULTING FROM ANNEXATION TO COUNTY SANITATION DISTRICT NO. 3 – ANNEXATION NO. 31

The Committee recommended the Board adopt Resolution No. 08-834.

9. EXPENSES OVER 90 DAYS

The Committee reviewed expense reimbursements submitted over 90 days of the date the expense was incurred. The Committee recommended they be approved by the Board of Directors.

The Committee further recommended that the expense reimbursement policy on expenses over 90 days be amended and continue the item to December 31, 2008.

10. WESTON BENSHOOF/ALSTON & BIRD CONTRACT AMENDMENT

Chief Financial Officer Scott Ota stated WRD currently has an agreement with Weston Benshoof as special counsel relating to the proposed groundwater storage agreement. Mr. Ota noted that staff has been notified that Weston Benshoof will merge with the law firm of Alston & Bird LLP, formally changing the name of the firm to Alston & Bird LLP. He explained that staff would like to update the contract to reflect the name change. He noted that Special Counsel Ed Casey would remain as the lead partner with respect to performing the legal services called for in the contract.

11. DIRECTORS EXPENSES

Director's expenses were reviewed and the Committee recommended the item be submitted to the Board for approval.

12. DIRECTORS REPORTS, INQUIRIES, AND REVIEW OF DIRECTIONS TO STAFF

Director Robles requested that the funding timeline for the Memorandum of Agreement with the Upper San Gabriel Valley Municipal Water District and Los Angeles County Sanitation District regarding an advanced water treatment plant in the Montebello Forebay be agendaized for discussion at the next Committee meeting.

13. ADJOURNMENT

With no further business for the Committee, the meeting was adjourned at 12:15 p.m.

Chairperson

ATTEST:

Director

UNAPPROVED
MINUTES

UNAPPROVED
MINUTES

**MINUTES OF OCTOBER 7, 2008
SPECIAL MEETING OF THE FINANCE COMMITTEE
OF THE BOARD OF DIRECTORS
WATER REPLENISHMENT DISTRICT OF SOUTHERN CALIFORNIA**

A special meeting of the Finance Committee of the Board of Directors of the Water Replenishment District of Southern California was held on October 7, 2008 at 11:35 a.m. at the District office, 4040 Paramount Boulevard, Lakewood, California. Director Sergio Calderon called the meeting to order and presided thereover. Deputy Secretary Abigail C. Andom recorded the minutes.

1. DETERMINATION OF A QUORUM

Directors: Sergio Calderon, Lillian Kawasaki
Staff: Robb Whitaker, Scott Ota, Jenna Shaunessy
Guest: Scott Henry, De La Rosa and Company and
Jeff Stava, Nossaman

2. PUBLIC COMMENT

None.

3. DEBT FINANCING UPDATE

Chief Financial Officer Scott Ota provided an overview of the bond financing process, identifying the District's financing team, their roles and responsibilities, the potential size of the bond issuance, importance of credit rating, and impact to the replenishment assessment.

Scott Henry of De La Rosa and Company, the District's underwriter, stated that in spite of the current tough market environment rates are still very attractive for a bond issuance and that the market should calm down in the next few weeks.

Mr. Ota referred the Committee to the financing documents that will be presented to the Board for their approval which would allow the District to be prepared to issue debt.

The Committee recommended the Board approve the financing documents, adopt the two resolutions for the Board and the District's financing corporation, and authorize the General Manager to proceed with the bond issuance when the market conditions are most favorable to the District.

4. **CONSIDERATION OF RESOLUTION NO. 08- 835 - A JOINT RESOLUTION OF THE BOARD OF SUPERVISORS OF THE COUNTY OF LOS ANGELES; THE BOARD OF DIRECTORS OF THE GREATER LOS ANGELES COUNTY VECTOR CONTROL DISTRICT; THE BOARD OF DIRECTORS OF THE COUNTY SANITATION DISTRICT NO. 18 OF LOS ANGELES COUNTY (COUNTY SANITATION DISTRICT NO. 18); AND THE BOARD OF DIRECTORS OF THE WATER REPLENISHMENT DISTRICT OF SOUTHERN CALIFORNIA APPROVING AND ACCEPTING THE NEGOTIATED EXCHANGE OF PROPERTY TAX REVENUES RESULTING FROM ANNEXATION OF L 004-2006 TO COUNTY LIGHTING MAINTENANCE DISTRICT 1687**

The Committee recommended the Board adopt Resolution No. 08-835.

5. **JANITORIAL SERVICES CONTRACT**

Mr. Ota stated that the District's current janitorial contract is about to expire and staff would like to renew their services for one year with an expanded scope of work. He explained that the District has been pleased with the service Jan-Pro had provided.

The Committee concurred with the staff recommendation to approve a contract extension with Jan-Pro Cleaning Systems for one year to expire October 31, 2009 at \$2,750/month, plus an allowance of 10% (\$3,300) for supplementary work on an as-needed basis as determined by staff.

6. **DIRECTORS EXPENSES**

Director's expenses were reviewed and the Committee recommended the item be submitted to the Board for approval.

7. **DIRECTORS REPORTS, INQUIRIES, AND REVIEW OF DIRECTIONS TO STAFF**

None.

8. **ADJOURNMENT**

With no further business for the Committee, the meeting was adjourned at 12:20 p.m.

Chairperson

ATTEST:

Director



MEMORANDUM

ITEM NO. 5

Prepared by: Binhyen Bui
Reviewed by: Scott M. Ota
Approved by: Robb Whitaker

DATE: OCTOBER 27, 2008
TO: FINANCE COMMITTEE
FROM: ROBB WHITAKER, GENERAL MANAGER
SUBJECT: DEMANDS

SUMMARY

At the request of the Finance Committee, the following items are attached:

1. The demands list for the period September 1st, 2008 – September 30th, 2008
2. The demands sorted by vendor with an additional column showing fiscal year-to-date payments

Demands Summary

Replenishment Fund	\$ 2,306,781.44
Clean Water Fund	<u>237,041.68</u>
Total	<u>\$ 2,543,823.12</u>

STAFF RECOMMENDATION

Receive and file the Demands for September 30, 2008.



DIRECTORS

ROBERT KATHERMAN, PRESIDENT
 LILLIAN Y. KAWASAKI, VICE PRESIDENT
 WILLARD H. MURRAY, JR., SECRETARY
 SERGIO CALDERON, TREASURER
 ALBERT ROBLES, DIRECTOR
 ROBB WHITAKER, P.E., GENERAL MANAGER

November 21, 2008

Board of Directors
 Water Replenishment District of Southern California

Submitted herewith for action by the Board of Directors are the following demands for the period ending September, 2008.

Check #	Payee	Description	Total	Replenishment Fund	Clean Water Fund
DD	ALBERT ROBLES	08/08 DIRECTORS COMPENSATION	1,730.78	1,626.93	103.85
DD	SERGIO J. CALDERON	09/08 DIRECTORS COMPENSATION	557.99	524.51	33.48
DD	SERGIO J. CALDERON	09/08 EXPENSE REIMBURSEMENT	395.01	371.31	23.70
DD	SERGIO J. CALDERON	08/08 DIRECTORS COMPENSATION	557.99	524.51	33.48
DD	WILLARD H. MURRAY, JR	08/08 DIRECTORS COMPENSATION	785.10	738.00	47.10
23782	LILLIAN Y. KAWASAKI	08/08 DIRECTORS COMPENSATION	552.52	519.35	33.17
23783	LILLIAN Y. KAWASAKI	07/08 DIRECTORS COMPENSATION	528.82	497.09	31.73
DD	ROBERT KATHERMAN	08/08 DIRECTORS COMPENSATION	941.54	885.05	56.49
23781	ROBERT KATHERMAN	08/08 EXPENSE REIMBURSEMENT	997.80	937.93	59.87
DD	AFSCME LOCAL 1902 UNION	PAYROLL DEDUCTION PAYMENT	406.60	350.42	56.18
DD	AFSCME LOCAL 1902 UNION	PAYROLL DEDUCTION PAYMENT	427.99	350.14	77.85
23778	L.A. COUNTY SHERIFF	PAYROLL DEDUCTION PAYMENT	556.80	523.39	33.41
DD	EDD	DIR STATE TAX PAYMENT	12.46	11.71	0.75
DD	EDD	STATE TAX PAYMENT	3,848.47	3,272.82	575.65
DD	EDD	STATE TAX PAYMENT	3,877.63	3,185.49	692.14
DD	PRUDENTIAL INSURANCE	DEFERRED COMPENSATION	16,122.83	14,013.82	2,109.01
DD	PRUDENTIAL INSURANCE	DEFERRED COMPENSATION	15,157.83	12,402.56	2,755.27
DD	PRUDENTIAL INSURANCE	DIR DEFERRED COMPENSATION	13,286.85	12,489.67	797.18
DD	PRUDENTIAL INSURANCE	DIR DEFERRED COMPENSATION	3,300.00	3,102.00	198.00
DD	EMPLOYEE PAYROLL	SALARY EXPENSE	60,337.04	52,340.59	7,996.45
DD	EMPLOYEE PAYROLL	SALARY EXPENSE	62,695.43	52,626.41	10,069.02
DD	IRS	FEDERAL TAX PAYMENT	24,207.40	20,775.52	3,431.88
DD	IRS	FEDERAL TAX PAYMENT	23,553.42	19,413.81	4,139.61
DD	IRS	DIR FEDERAL TAX PAYMENT	2,583.85	2,428.81	155.04
DD	IRS	DIR FEDERAL TAX PAYMENT	844.02	793.38	50.64
DD	PERS	PERS PAYMENT	24,260.45	21,018.99	3,241.46
DD	PERS	PERS PAYMENT	24,743.71	20,615.57	4,128.14
DD	PERS	DIRECTORS' PERS PYMT	247.00	232.20	14.80
DD	PARS	DIRECTORS' PARS PYMT	3,551.26	3,338.17	213.09
DD	PARS	DIRECTORS' PARS PYMT	755.59	710.25	45.34
ACH080908	WBMWD	07/08 WATER PURCHASE	851,067.32	851,067.32	-
23719	ABEL GUTIERREZ	ASSEMBLY SPEAKER PHOTOS	225.00	211.50	13.50
23720	ADT SECURITY SERVICES	09/08 MAINT SERVICE	88.48	83.17	5.31
23721	AMY'S TROPHIES	NAME BADGES & PLATES - TW	32.48	30.53	1.95
23722	AQUARIUM OF THE PACIFIC	2008 IAFTM WTRSHED EDU GRANT	50,000.00	47,000.00	3,000.00
23723	AQUARIUM OF THE PACIFIC	IAFTM SCHOOL CLASSES	5,000.00	4,700.00	300.00
23724	AUDIO VISUAL INNOVATION	AUDIO MAINT SERVICE	275.00	258.50	16.50
23725	BZ DISPOSAL SERVICES	08/08 WASTE SERVICE	176.23	165.66	10.57
23726	CALIFORNIA WATER SERVICE	WATER USAGE - 4635	52.57	49.41	3.16
23727	CARSON CHAMBER	2008-09 MEMBERSHIP DUES	350.00	329.00	21.00
23728	COLORADO RIVER WTR USERS ASSOC	2008 MEMBERSHIP DUES - SC	20.00	18.80	1.20
23729	CONTROLLED KEY SYSTEM	DOOR MAINT SERVICE	579.18	544.43	34.75
23730	CTR FOR PROF EDUCATION	REGISTRATION FEE - SO	25.50	23.97	1.53
23731	DOWNEY CHAMBER	9/01/08 - 9/01/09 MEMB DUE	290.00	272.60	17.40
23732	SOUTHWEST WATER COMPANY	002: 07/08 O & M SERVICE	24,155.35	-	24,155.35
23733	EMEDCO	SUPPLIES - ANTI SLIP TAPE	447.68	420.82	26.86
23734	FEDERAL EXPRESS	FEDEX SERVICE	143.18	125.73	17.45
23735	FM THOMAS AIR CONDITIONING	AC MAINT SERVICE	2,958.81	2,781.28	177.53
23736	HENRY'S CLEANERS	MAINT SERVICE - FRIDGE	100.00	94.00	6.00
23737	H. TOJI & COMPANY	WINDOW DIRECTIONAL SIGNS	465.21	437.30	27.91
23738	IMMERSIV MEDIA	07/08 PROF SERVICE	100.00	94.00	6.00
23739	INTER-TEL TECHNOLOGIES	TECHNICAL SUPPORT	275.00	258.50	16.50
23740	JAN-PRO CLEANING	09/08 MAINT SERVICE	1,230.00	1,156.20	73.80
23741	KELLY PAPER	PAPER SUPPLIES	230.23	216.41	13.82
23742	LA EXPRESS ONE	COURIER SERVICE	67.50	63.45	4.05
23743	LAKEWOOD, CITY OF	MONTHLY WTR USAGE - 0015	73.67	69.25	4.42
23744	LAKEWOOD, CITY OF	MONTHLY WTR USAGE - 0007	30.90	29.05	1.85



Check #	Payee	Description	Total	Replenishment Fund	Clean Water Fund
23745	LONG BEACH, CITY OF	001: 07/08 O & M SERVICE	189,656.61	189,656.61	-
23746	LONG BEACH, CITY OF	07/08 WATER PURCHASE	160,569.00	160,569.00	-
23747	VOID	VOID	-	-	-
23748	LOS ANGELES TIMES	06/30/08 - 9/22/08 DAILY NEWSPAPER	67.60	63.54	4.06
23749	MARTIN E WHELAN, JR.	09/08 MEDICAL PREMIUM	740.09	695.68	44.41
23750	MONSTER WORLDWIDE	JOB POSTING THRU 6/17/09	1,600.00	1,504.00	96.00
23751	MWH LABORATORIES	07/08 LAB SERVICES	38,316.00	37,240.00	1,076.00
23752	VOID	VOID	-	-	-
23753	OCB REPROGRAPHICS	032: LANDSCAPE PLAN COPIES	426.22	400.65	25.57
23754	PUMPMAN INC	004: MAINT SERVICE	1,854.00	1,854.00	-
23755	PITNEY BOWES	MONTHLY POSTAGE USAGE	750.00	705.00	45.00
23756	SOUTH BAY LATINO CHAMBER	SBGCC GOLF TOURNAMENT	5,000.00	4,700.00	300.00
23757	STANDARD INSURANCE COMPANY	09/08 STD/LTD PREMIUM	1,249.00	1,174.06	74.94
23758	STAR OFFICE PRODUCTS	OFFICE SUPPLIES	118.52	111.41	7.11
23759	THE CASTLE PRESS	2008 SUMMER NEWSLETTER	12,863.36	12,091.55	771.81
23760	VOID	VOID	-	-	-
23761	TRUSSELL TECHNOLOGIES	001: 07/08 PROF SERVICE	28,617.66	28,617.66	-
23762	UNITED RENTALS NORTHWEST	004: EQUIPMENT RENTAL	3,806.64	3,806.64	-
23763	WEST BASIN WATER ASSOC	ANNUAL DINNER MEETING	150.00	141.00	9.00
23764	WILMINGTON CHAMBER	8/01/08 - 7/31/09 MEMB DUE	340.00	319.60	20.40
23765	X-LGENT PRINTING INC.	PROMO ITEM - TOTE BAGS	1,703.39	1,601.19	102.20
23766	X-LGENT PRINTING INC.	PROMO ITEM - BEACH BALLS	1,390.46	1,307.03	83.43
23767	X-LGENT PRINTING INC.	PROMO ITEM - COOLER BAGS	5,637.82	5,299.55	338.27
23768	XO CORPORATION	PHONE CHARGES THRU 9/14/08	106.75	100.35	6.40
23769	ENVIRONMENTAL SIMULATIONS	GRNDWTR VISTAS V5 UPGRADE	315.00	157.50	157.50
23770	ROSE & KINDEL	07/08 LEGISLATIVE SERVICE	15,000.00	14,400.00	600.00
23771	NALEO EDUCATIONAL FUND	MEMBERSHIP DUE - AR	100.00	94.00	6.00
23772	LOS ANGELES COUNTY DPW	004: 8/1/2008 - 7/31/2009 LEASE 98-02	600.00	564.00	36.00
23773	STAR OFFICE PRODUCTS	OFFICE SUPPLIES	1,033.87	971.83	62.04
23774	TORRANCE, CITY OF	002: 09/08 PLANT SITE RENT	2,840.22	-	2,840.22
23775	SEE PAYROLL	SEE PAYROLL	-	-	-
23776	SEE PAYROLL	SEE PAYROLL	-	-	-
23777	MEYERS & NAVE	06/08 BOARD OF DIRECTORS	41,211.15	37,702.50	3,508.65
23779	VOID	VOID	-	-	-
23780	VOID	VOID	-	-	-
23781	SEE PAYROLL	SEE PAYROLL	-	-	-
23782	SEE PAYROLL	SEE PAYROLL	-	-	-
23783	SEE PAYROLL	SEE PAYROLL	-	-	-
23784	ADVANCED DOCUMENT SOLUTIONS	LIBERTYNET MAINT SERVICE	7,909.89	7,435.30	474.59
23785	L. A. BROTHERHOOD CRUSADE	40th AWARD DINNER	1,500.00	1,410.00	90.00
23786	CALIFORNIA WTR SERVICE CO	012: MAINT SERVICE	49,144.60	-	49,144.60
23787	COSTCO	KITCHEN SUPPLIES	274.20	257.75	16.45
23788	COUNTY SANITATION DISTRICT 2	CA WTR CRISIS MEETING - BS	35.00	32.90	2.10
23789	DELL	COMPUTER SUPPLIES	28,300.74	26,602.70	1,698.04
23790	SOUTHWEST WATER COMPANY	002: MAINT SERVICE THRU 7/31/08	4,542.05	-	4,542.05
23791	EMS-I	025: SOFTWARE MAINT SERVICE	772.50	386.25	386.25
23792	FEDERAL EXPRESS	FEDEX SERVICE	271.32	202.41	68.91
23793	FM THOMAS AIR CONDITIONING	AIR CONDITION SERVICE	487.50	458.25	29.25
23794	HELITAC AVIATION	CHARTER SERVICE	1,425.00	1,339.50	85.50
23795	HELPMATES STAFFING	TEMP SERVICE THRU 8/24/08	1,282.17	1,205.24	76.93
23796	VOID	VOID	-	-	-
23797	LOS ANGELES CHAMBER	10/1/08-9/30/09 MEMB DUES	1,575.00	1,480.50	94.50
23798	MR ROOTER PLUMBING	MAINT SERVICE	500.00	470.00	30.00
23799	NORWALK CHAMBER	CHAMBER LUNCHEON	50.00	47.00	3.00
23800	PICO RIVERA CHAMBER	9/1/08-8/31/09 MEMB DUES	125.00	117.50	7.50
23801	PITNEY BOWES	EQUIPMENT TAX	118.10	111.01	7.09
23802	RAPIDFORMS	LASER CHECKS & ENVELOPES	348.72	327.80	20.92
23803	ROBERT E. BUSH CORP	08/08 PROF SERVICE	3,000.00	2,820.00	180.00
23804	ROSE & KINDEL	08/08 LEGISLATIVE SERVICE	15,569.00	14,934.86	634.14
23805	RUEKERT & MIELKE	025: PROF SERVICE THRU 7/18/08	3,467.00	-	3,467.00
23806	STRONGARM ENVIRONMENTAL	004: TECHNICAL SUPPORT	2,190.00	2,190.00	-
23807	TESTAMERICA	006: 07/08 PROF SERVICE	1,032.80	-	1,032.80
23808	REGENTS OF THE UNIV OF CA	001: PROF SERVICE THRU 6/30/08	31,464.13	31,464.13	-
23809	UNITED RENTALS NORTHWEST	004: EQUIPMENT RENTAL	1,103.89	1,103.89	-
23810	VERIZON WIRELESS	MONTHLY CELL PHONE SVC	1,143.72	1,075.10	68.62
23811	XEROX CORPORATION	08/08 COPIER - CR7665	11,875.10	11,162.59	712.51
23812	MILLENNIUM ADVOCATES	04/08 LEGISLATIVE SERVICE	12,606.46	11,850.07	756.39
23813	NORWALK CHAMBER	FY 08/09 MEMBERSHIP DUE	360.00	338.40	21.60
23814	MALCOLM PIRNIE	JOB POSTINGS	200.00	188.00	12.00
23815	ACWA - HBA	09/08 MED/DEN/LIFE PREMIUM	33,157.14	31,167.70	1,989.44
23816	CHEVRON AND TEXACO	08/08 FUEL CHARGES	110.96	110.96	-
23817	GORDON THOMAS HONEYWELL	PROF SERVICE THRU 7/31/08	31,695.55	29,793.82	1,901.73
23818	VERIZON BUSINESS	MONTHLY INTERNET SERVICE	533.00	501.02	31.98
23819	PHILLIPS 66-CONOCO-76	MONTHLY FUEL CHARGES	1,177.86	983.36	194.50
23820	SOUTHERN CALIFORNIA EDISON	08/08 ENERGY USAGE	8,097.63	7,611.77	485.86
23821	THE GAS COMPANY	MONTHLY UTILITY CHARGES	703.81	661.58	42.23
23822	VERIZON CALIFORNIA	MONTHLY PHONE CHARGES	347.75	326.89	20.86
23823	1-800-CONFERENCE(R)	CONFERENCE CALLS	311.74	293.04	18.70
23824	AT&T	002: MONTHLY PHONE SVC	178.88	-	178.88
23825	SOUTHERN CALIFORNIA EDISON	002: ENERGY USAGE THRU 9/5/08	23,151.92	-	23,151.92
23826	THE SOURCE	BACKGROUND CHECK - PL & PP	237.00	222.78	14.22

Check #	Payee	Description	Total	Replenishment Fund	Clean Water Fund
23827	SEE PAYROLL	SEE PAYROLL	-	-	-
23828	SEE PAYROLL	SEE PAYROLL	-	-	-
23829	SEE PAYROLL	SEE PAYROLL	-	-	-
23830	ASCE MLAB	REGISTRATION FEE - BS & TW	110.00	110.00	-
23831	DANNY L. GLASGOW	MEDICAL REIMBURSEMENT-DG	920.95	865.69	55.26
23832	ELSIE E. BAKONIS	MEDICAL REIMBURSEMENT-EB	421.00	395.74	25.26
23833	F&M BANK: CC PAYMENT	08/08 CC CHARGES	3,084.61	2,899.54	185.07
23834	LOS ANGELES, CITY OF DWP	7/21/08-8/19/08 WATER PURCHASE	156,364.56	156,364.56	-
23835	COUNTY SANITATION DISTRICT 2	001: 1ST QTR WWTS PAYMENT	27,158.00	27,158.00	-
23836	COUNTY SANITATION DISTRICT 2	002: 1ST QTR WWTS PAYMENT	15,769.00	-	15,769.00
23837	INTERIOR PLANT DESIGN	001: 09/08 MAINT SERVICE	1,025.00	899.50	125.50
23838	ACWA - HBA	10/08 MED/DEN/LIFE PREMIUM	33,898.55	31,864.62	2,033.93
23839	ADT SECURITY SERVICES	10/08 MAINT SERVICE	88.48	83.17	5.31
23840	AMY'S TROPHIES & SPECIALITIES	AWARD ENGRAVING	297.14	279.31	17.83
23841	VOID	VOID	-	-	-
23842	BOOKMAN-EDMONSTON	023: PROF SERVICE THRU 8/30/08	675.00	675.00	-
23843	DEPT OF TOXIC SUBSTANCES CONTROL	006: 7/1/07- 6/30/08 PROF SERVICE	11,886.92	-	11,886.92
23844	CONTROLLED KEY SYSTEM	KEY FOB INSTALL - LEASE SPACE	2,232.40	2,098.46	133.94
23845	COUNTY SANITATION DISTRICT 2	07/08 WATER PURCHASE - SJC	56,762.55	56,762.55	-
23846	COUNTY SANITATION DISTRICT 2	07/08 WATER PURCHASE - WN	3,549.00	3,549.00	-
23847	DEPARTMENT OF CONSUMER AFFAIRS	CPA LICENSE RENEWAL - SO	200.00	188.00	12.00
23848	EARTHLINK INC.	MONTHLY DIAL-UP INTERNET SVC	23.95	22.51	1.44
23849	SOUTHWEST WATER COMPANY	08/08 O & M SERVICE	22,342.94	-	22,342.94
23850	EMCA CLERK (US POSTAL)	POSTAGE DEPOSIT	25.31	23.79	1.52
23851	EXXON MOBIL FLEET/GECC	MONTHLY FUEL CHARGES	958.49	900.98	57.51
23852	FEDERAL EXPRESS	FEDEX SERVICE	110.05	103.44	6.61
23853	FM THOMAS AIR CONDITIONING	AIR CONDITION SERVICE	5,484.00	5,154.96	329.04
23854	GOLDEN STATE ENVIRONMENTAL	004: 07/08 PROF SERVICE	5,914.74	5,914.74	-
23855	HELPMATES STAFFING	TEMP SERVICE THRU 9/7/08	5,840.46	5,490.03	350.43
23856	HENRY'S CLEANERS	MAINT SERVICE - MINI BLINDS	280.00	263.20	16.80
23857	IN-SITU	011: FIELD EQUIP MAINT SVC	2,424.62	1,212.31	1,212.31
23858	KONE	9/01/08-11/30/08 MAINT SERVICE	153.12	143.93	9.19
23859	LEGISLATIVE ADVOCACY GROUP	08/08 LEGISLATIVE SERVICE	7,500.00	7,050.00	450.00
23860	LONG BEACH CITY COLLEGE	TENANT IMPROVEMENT - LEASE SPACE	45,000.00	42,300.00	2,700.00
23861	MILLENNIUM ADVOCATES	07/08 LEGISLATIVE SERVICE	12,500.00	11,750.00	750.00
23862	MWH LABORATORIES	08/08 LAB SERVICES	17,418.00	17,012.50	405.50
23863	NATIONAL GROUND WATER ASSOC	REGISTRATION FEE - MK	130.00	65.00	65.00
23864	NELLOR ENVIRONMENTAL	004: 08/08 PROF SERVICE	2,565.00	2,565.00	-
23865	NEW RESOURCES GROUP	PROMO ITEM - HOSE NOZZLES	9,732.50	9,148.55	583.95
23866	NORWALK PRINTING COMPANY	LETTERHEADS & ENVELOPES	453.19	426.00	27.19
23867	OCB REPROGRAPHICS	032: LANDSCAPE PLAN COPIES	362.52	340.77	21.75
23868	PARS	07/08 REP FEES	500.00	470.00	30.00
23869	POSTAGE BY PHONE	POSTAGE DEPOSIT	3,000.00	2,820.00	180.00
23870	RMC WATER AND ENVIRONMENT	005: 6/28/08-8/29/08 PROF SERVICE	14,931.30	14,931.30	-
23871	STANLEY CONVERGENT SECURITY	10/1/08-12/31/08 MAINT SERVICE	240.00	225.60	14.40
23872	STAR OFFICE PRODUCTS	OFFICE SUPPLIES	639.21	600.86	38.35
23873	TOTAL CONCEPT LANDSCAPE ARCHIT	LANDSCAPE PLAN REVIEW	3,890.00	3,656.60	233.40
23874	TESTAMERICA	006: 08/08 PROF SERVICE	4,377.80	-	4,377.80
23875	VOID	VOID	-	-	-
23876	WESTERN EXTERMINATOR	08/08 MAINT SERVICE	65.00	61.10	3.90
23877	WESTON BENSHOOF	005: 07/08 LEGAL SERVICE	20,771.41	20,771.41	-
23878	XEROX CORPORATION	09/08 COPIER - CR7655	1,542.79	1,450.22	92.57
23879	YSI INCORPORATED	011: FIELD SUPPLIES	379.60	189.80	189.80
23880	CA-NV SECTION, AWWA	CAPITAL CAMPAIGN	500.00	470.00	30.00
23881	SOUTHWEST WATER COMPANY	002: 08/08 MAINT SERVICE	600.00	-	600.00
23882	VASQUEZ & COMPANY LLP	06/08 PROF SERVICE	10,000.00	9,400.00	600.00
Total Demands from September 1, 2008 to September 31, 2008			2,543,823.12	2,306,781.44	237,041.68

Robb Whitaker, P.E., General Manager

Water Replenishment District of Southern California
Demands List - Current and YTD By Vendor

<u>Payee</u>	<u>Description</u>	<u>Current Demands</u>	<u>YTD Demands</u>
PAYROLL	BENEFIT/DEDUCTION/REIMBURSEMENT	102,816.91	345,877.29
PAYROLL	PAYROLL	123,032.47	437,988.97
PAYROLL	TAXES	58,927.25	211,435.40
ALBERT ROBLES	08/08 DIRECTORS COMPENSATION	1,730.78	5,071.58
SERGIO J. CALDERON	09/08 DIRECTORS COMPENSATION	557.99	1,835.47
SERGIO J. CALDERON	09/08 EXPENSE REIMBURSEMENT	395.01	2,230.48
SERGIO J. CALDERON	08/08 DIRECTORS COMPENSATION	557.99	2,788.47
ROBERT KATHERMAN	08/08 DIRECTORS COMPENSATION	941.54	2,518.44
ROBERT KATHERMAN	08/08 EXPENSE REIMBURSEMENT	997.80	2,210.38
WILLARD H. MURRAY, JR.	08/08 DIRECTORS COMPENSATION	785.10	2,061.68
LILLIAN Y. KAWASAKI	08/08 DIRECTORS COMPENSATION	552.52	1,584.96
LILLIAN Y. KAWASAKI	07/08 DIRECTORS COMPENSATION	528.82	2,113.78
1-800-CONFERENCE(R)	CONFERENCE CALLS	311.74	2,009.72
ABEL GUTIERREZ	ASSEMBLY SPEAKER PHOTOS	225.00	225.00
ACWA - HBA	09/08 MED/DEN/LIFE PREMIUM	33,157.14	101,831.19
ACWA - HBA	10/08 MED/DEN/LIFE PREMIUM	33,898.55	135,729.74
ADT SECURITY SERVICES	09/08 MAINT SERVICE	88.48	265.44
ADT SECURITY SERVICES	10/08 MAINT SERVICE	88.48	353.92
ADVANCED DOCUMENT SOLUTIONS	LIBERTYNET MAINT SERVICE	7,909.89	7,909.89
AMY'S TROPHIES	NAME BADGES & PLATES - TW	32.48	32.48
AMY'S TROPHIES	AWARD ENGRAVING	297.14	329.62
AQUARIUM OF THE PACIFIC	2008 IAFTM WTRSHED EDU GRANT	50,000.00	50,000.00
AQUARIUM OF THE PACIFIC	IAFTM SCHOOL CLASSES	5,000.00	55,000.00
ASCE MLAB	REGISTRATION FEE - BS & TW	110.00	110.00
AT&T	002: MONTHLY PHONE SVC	178.88	713.06
AUDIO VISUAL INNOVATION	AUDIO MAINT SERVICE	275.00	275.00
BOOKMAN-EDMONSTON	023: PROF SERVICE THRU 8/30/08	675.00	6,844.80
BZ DISPOSAL SERVICES	08/08 WASTE SERVICE	176.23	523.39
CALIFORNIA WATER SERVICE	WATER USAGE	52.57	150.86
CALIFORNIA WTR SERVICE CO	012: MAINT SERVICE	49,144.60	49,144.60
CA-NV SECTION, AWWA	CAPITAL CAMPAIGN	500.00	500.00
CARSON CHAMBER	2008-09 MEMBERSHIP DUES	350.00	350.00
CHEVRON AND TEXACO	08/08 FUEL CHARGES	110.96	1,811.40
COLORADO RIVER WTR USERS ASSOC	2008 MEMBERSHIP DUES - SC	20.00	40.00
CONTROLLED KEY SYSTEM	DOOR MAINT SERVICE	579.18	579.18
CONTROLLED KEY SYSTEM	KEY FOB INSTALL - LEASE SPACE	2,232.40	2,811.58
COSTCO	KITCHEN SUPPLIES	274.20	973.41
COUNTY SANITATION DISTRICT 2	001: 1ST QTR WWTS PAYMENT	27,158.00	277,342.99
COUNTY SANITATION DISTRICT 2	002: 1ST QTR WWTS PAYMENT	15,769.00	293,111.99
COUNTY SANITATION DISTRICT 2	07/08 WATER PURCHASE - SJC	56,762.55	349,874.54
COUNTY SANITATION DISTRICT 2	07/08 WATER PURCHASE - WN	3,549.00	353,423.54
COUNTY SANITATION DISTRICT 2	CA WTR CRISIS MEETING - BS	35.00	353,458.54
CTR FOR PROF EDUCATION	REGISTRATION FEE - SO	25.50	25.50
DANNY L. GLASGOW	MEDICAL REIMBURSEMENT-DG	920.95	920.95
DELL COMPUTER	COMPUTER SUPPLIES	28,300.74	28,300.74
DEPARTMENT OF CONSUMER AFFAIRS	CPA LICENSE RENEWAL - SO	200.00	200.00
DEPT OF TOXIC SUBSTANCES CONTROL	006: 7/1/07- 6/30/08 PROF SERVICE	11,886.92	11,886.92
DOWNEY CHAMBER	9/01/08 - 9/01/09 MEMB DUE	290.00	290.00
EARTHLINK INC.	MONTHLY DIAL-UP INTERNET SVC	23.95	95.80
ELSIE E. BAKONIS	MEDICAL REIMBURSEMENT-EB	421.00	1,053.92
EMCA CLERK (US POSTAL)	POSTAGE DEPOSIT	25.31	50.62
EMEDCO	SUPPLIES - ANTI SLIP TAPE	447.68	447.68
EMS-I	025: SOFTWARE MAINT SVC	772.50	772.50
ENVIRONMENTAL SIMULATIONS	GRNDWTR VISTAS V5 UPGRADE	315.00	2,715.00
EXXON MOBIL FLEET/GECC	MONTHLY FUEL CHARGES	958.49	1,212.68
F&M BANK: CC PAYMENT	08/08 CC CHARGES	3,084.61	11,630.27
FEDERAL EXPRESS	FEDEX SERVICE	110.05	842.62
FEDERAL EXPRESS	FEDEX SERVICE	143.18	985.80
FEDERAL EXPRESS	FEDEX SERVICE	271.32	1,257.12
FM THOMAS AIR CONDITIONING	AIR CONDITION SERVICE	487.50	10,227.09
FM THOMAS AIR CONDITIONING	AIR CONDITION SERVICE	2,958.81	13,185.90
FM THOMAS AIR CONDITIONING	AIR CONDITION SERVICE	5,484.00	18,669.90

Water Replenishment District of Southern California
 Demands List - Current and YTD By Vendor

<u>Payee</u>	<u>Description</u>	<u>Current Demands</u>	<u>YTD Demands</u>
GOLDEN STATE ENVIRONMENTAL	004: 07/08 PROF SERVICE	5,914.74	5,914.74
GORDON THOMAS HONEYWELL	PROF SERVICE THRU 7/31/08	31,695.55	118,557.14
H. TOJI & COMPANY	WINDOW DIRECTIONAL SIGNS	465.21	465.21
HELITAC AVIATION	CHARTER SERVICE	1,425.00	1,425.00
HELPMATES STAFFING	TEMP SERVICE THRU 8/24/08	1,282.17	10,975.80
HELPMATES STAFFING	TEMP SERVICE THRU 9/7/08	5,840.46	16,816.26
HENRY'S CLEANERS	MAINT SERVICE - FRIDGE	100.00	200.00
HENRY'S CLEANERS	MAINT SERVICE - MINI BLINDS	280.00	480.00
IMMERSIV MEDIA	07/08 PROF SERVICE	100.00	11,687.50
IN-SITU	011: FIELD EQUIP MAINT SVC	2,424.62	18,445.89
INTERIOR PLANT DESIGN	001: 09/08 MAINT SERVICE	1,025.00	3,252.50
INTER-TEL TECHNOLOGIES	TECHNICAL SUPPORT	275.00	1,536.22
JAN-PRO CLEANING	09/08 MAINT SERVICE	1,230.00	4,890.00
KELLY PAPER	PAPER SUPPLIES	230.23	230.23
KONE	9/01/08-11/30/08 MAINT SERVICE	153.12	153.12
L. A. BROTHERHOOD CRUSADE	40th AWARD DINNER	1,500.00	1,500.00
LA EXPRESS ONE	COURIER SERVICE	67.50	67.50
LAKESWOOD, CITY OF	MONTHLY WTR USAGE - 0007	30.90	1,135.47
LAKESWOOD, CITY OF	MONTHLY WTR USAGE - 0015	73.67	1,209.14
LEGISLATIVE ADVOCACY GROUP	08/08 LEGISLATIVE SERVICE	7,500.00	30,000.00
LONG BEACH CITY COLLEGE	TENANT IMPROVEMENT - LEASE SPACE	45,000.00	45,000.00
LONG BEACH, CITY OF	001: 07/08 O & M SERVICE	189,656.61	906,089.06
LONG BEACH, CITY OF	07/08 WATER PURCHASE	160,569.00	1,066,658.06
LOS ANGELES CHAMBER	10/1/08-9/30/09 MEMB DUES	1,575.00	1,575.00
LOS ANGELES COUNTY DPW	004: 8/1/2008 - 7/31/2009 LEASE 98-02	600.00	600.00
LOS ANGELES TIMES	06/30/08 - 9/22/08 DAILY NEWSPAPER	67.60	67.60
LOS ANGELES, CITY OF DWP	7/21/08-8/19/08 WATER PURCHASE	156,364.56	662,628.78
MALCOLM PIRNIE	JOB POSTINGS	200.00	200.00
MARTIN E WHELAN. JR.	09/08 MEDICAL PREMIUM	740.09	2,228.29
MEYERS & NAVE	06/08 BOARD OF DIRECTORS	41,211.15	61,934.71
MILLENNIUM ADVOCATES	04/08 LEGISLATIVE SERVICE	12,606.46	37,606.46
MILLENNIUM ADVOCATES	07/08 LEGISLATIVE SERVICE	12,500.00	50,106.46
MONSTER WORLDWIDE	JOB POSTING THRU 6/17/09	1,600.00	1,600.00
MR ROOTER PLUMBING	MAINT SERVICE	500.00	500.00
MWH LABORATORIES	07/08 LAB SERVICES	38,316.00	249,999.00
MWH LABORATORIES	08/08 LAB SERVICES	17,418.00	267,417.00
NALEO EDUCATIONAL FUND	MEMBERSHIP DUE - AR	100.00	100.00
NATIONAL GROUND WATER ASSOC	REGISTRATION FEE - MK	130.00	130.00
NELLOR ENVIRONMENTAL	004: 08/08 PROF SERVICE	2,565.00	4,860.00
NEW RESOURCES GROUP	PROMO ITEM - HOSE NOZZLES	9,732.50	9,732.50
NORWALK CHAMBER	CHAMBER LUNCHEON	50.00	50.00
NORWALK CHAMBER	FY 08/09 MEMBERSHIP DUE	360.00	410.00
NORWALK PRINTING COMPANY	LETTERHEADS & ENVELOPES	453.19	822.33
OCB REPROGRAPHICS	032: LANDSCAPE PLAN COPIES	362.52	2,589.84
OCB REPROGRAPHICS	032: LANDSCAPE PLAN COPIES	426.22	3,016.06
PARS	07/08 REP FEES	500.00	2,000.00
PHILLIPS 66-CONOCO-76	MONTHLY FUEL CHARGES	1,177.86	3,776.67
PICO RIVERA CHAMBER	9/1/08-8/31/09 MEMB DUES	125.00	125.00
PITNEY BOWES	EQUIPMENT TAX	118.10	1,618.10
PITNEY BOWES	MONTHLY POSTAGE USAGE	750.00	2,368.10
POSTAGE BY PHONE	POSTAGE DEPOSIT	3,000.00	3,000.00
PUMPMAN INC	004: MAINT SERVICE	1,854.00	1,854.00
RAPIDFORMS	LASER CHECKS & ENVELOPES	348.72	348.72
REGENTS OF THE UNIV OF CA	001: PROF SERVICE THRU 6/30/08	31,464.13	31,464.13
RMC WATER AND ENVIRONMENT	005: 6/28/08-8/29/08 PROF SERVICE	14,931.30	26,558.79
ROBERT E. BUSH CORP	08/08 PROF SERVICE	3,000.00	9,000.00
ROSE & KINDEL	07/08 LEGISLATIVE SERVICE	15,000.00	30,013.25
ROSE & KINDEL	08/08 LEGISLATIVE SERVICE	15,569.00	45,582.25
RUEKERT & MIELKE	025: PROF SERVICE THRU 7/18/08	3,467.00	33,380.21
SOUTH BAY LATINO CHAMBER	SBLCC GOLF TOURNAMENT	5,000.00	5,000.00
SOUTHERN CALIFORNIA EDISON	002: ENERGY USAGE THRU 9/5/08	23,151.92	81,243.62
SOUTHERN CALIFORNIA EDISON	08/08 ENERGY USAGE	8,097.63	89,341.25
SOUTHWEST WATER COMPANY	002: 07/08 O & M SERVICE	24,155.35	120,003.48

Water Replenishment District of Southern California
 Demands List - Current and YTD By Vendor

<u>Payee</u>	<u>Description</u>	<u>Current Demands</u>	<u>YTD Demands</u>
SOUTHWEST WATER COMPANY	002: 08/08 MAINT SERVICE	600.00	120,603.48
SOUTHWEST WATER COMPANY	002: MAINT SERVICE THRU 7/31/08	4,542.05	125,145.53
SOUTHWEST WATER COMPANY	08/08 O & M SERVICE	22,342.94	147,488.47
STANDARD INSURANCE COMPANY	09/08 STD/LTD PREMIUM	1,249.00	3,803.00
STANLEY CONVERGENT SECURITY SOLUTIONS	10/1/08-12/31/08 MAINT SVC	240.00	1,060.50
STAR OFFICE PRODUCTS	OFFICE SUPPLIES	118.52	1,387.24
STAR OFFICE PRODUCTS	OFFICE SUPPLIES	639.21	2,026.45
STAR OFFICE PRODUCTS	OFFICE SUPPLIES	1,033.87	3,060.32
STRONGARM ENVIRONMENTAL	004: TECHNICAL SUPPORT	2,190.00	11,125.00
TESTAMERICA	006: 07/08 PROF SERVICE	1,032.80	18,113.60
TESTAMERICA	006: 08/08 PROF SERVICE	4,377.80	22,491.40
THE CASTLE PRESS	2008 SUMMER NEWSLETTER	12,863.36	35,464.65
THE GAS COMPANY	MONTHLY UTILITY CHARGES	703.81	2,383.63
THE SOURCE	BACKGROUND CHECK - PL & PP	237.00	316.00
TORRANCE, CITY OF	002: 09/08 PLANT SITE RENT	2,840.22	48,520.66
TOTAL CONCEPT LANDSCAPE ARCHITECT	LANDSCAPE PLAN REVIEW	3,890.00	3,890.00
TRUSSELL TECHNOLOGIES	001: 07/08 PROF SERVICE	28,617.66	56,197.71
UNITED RENTALS NORTHWEST	004: EQUIPMENT RENTAL	1,103.89	5,265.06
UNITED RENTALS NORTHWEST	004: EQUIPMENT RENTAL	3,806.64	9,071.70
VASQUEZ & COMPANY LLP	06/08 PROF SERVICE	10,000.00	10,000.00
VERIZON BUSINESS	MONTHLY INTERNET SERVICE	533.00	2,665.00
VERIZON CALIFORNIA	MONTHLY PHONE CHARGES	347.75	1,385.85
VERIZON WIRELESS	MONTHLY CELL PHONE SVC	1,143.72	4,726.31
WBMWD	07/08 WATER PURCHASE	851,067.32	2,600,672.62
WEST BASIN WATER ASSOC	ANNUAL DINNER MEETING	150.00	150.00
WESTERN EXTERMINATOR	08/08 MAINT SERVICE	65.00	195.00
WESTON BENSHOOF	005: 07/08 LEGAL SERVICE	20,771.41	43,970.41
WILMINGTON CHAMBER	8/01/08 - 7/31/09 MEMB DUE	340.00	340.00
XEROX CORPORATION	08/08 COPIER - CR7665	11,875.10	18,996.76
XEROX CORPORATION	09/08 COPIER - CR7655	1,542.79	20,539.55
X-LGENT PRINTING INC.	PROMO ITEM - BEACH BALLS	1,390.46	22,745.39
X-LGENT PRINTING INC.	PROMO ITEM - COOLER BAGS	5,637.82	28,383.21
X-LGENT PRINTING INC.	PROMO ITEM - TOTE BAGS	1,703.39	30,086.60
XO CORPORATION	PHONE CHARGES THRU 9/14/08	106.75	351.81
YSI INCORPORATED	011: FIELD SUPPLIES	379.60	379.60
		2,543,823.12	10,662,756.74



MEMORANDUM

ITEM NO. 6

Prepared by: Scott M. Ota

Reviewed by: Scott M. Ota

Approved by: Robb Whitaker

DATE: OCTOBER 27, 2008
TO: FINANCE COMMITTEE
FROM: ROBB WHITAKER, GENERAL MANAGER
SUBJECT: FINANCIAL STATEMENTS –JULY 31, 2008

The attached financial statements include the Statement of Net Assets (Balance Sheet) as of July 31, 2008 and the Statement of Revenues, Expenditures and Changes in Net Assets (Income Statement) for the month ending July 31, 2008. Explanation of selected account balances are as follows:

Statement of Net Assets

ASSETS

Cash – Decreased about \$532,000 was primarily due to semi-annual interest and principal payment of the 2004 debt issuance.

Accounts Receivable – There was an increase of approximately \$812,000 in the accounts receivable subsidiary ledger primarily due to additional usage of seasonal water in the months of May, June, and July 2008 (replenishment assessment payments are received three months after we recognize the revenue).

Construction in Progress – The Construction in Progress account increased by about \$127,000 due to expenses related to the regional groundwater monitoring well drilling program.

LIABILITIES

Accounts Payable – Due to the June 30, 2008 fiscal year end, the WRD recognized a greater number of payments in June than July. This accounts for the decrease in the accounts payable subsidiary ledger of \$381,000.

Interest Payable and Long Term Debt Liability - Decreased due to semi-annual interest and principle payment of the 2004 debt issuance (see cash above)

NET ASSETS

Invested in Capital Assets – This is a formula and is related to the changes in all capital asset accounts:

<u>Accounts</u>	<u>Change</u>
Construction-In-Progress	\$ 127,018
Accumulated Depreciation	(188,756)
Total	<u>\$ (61,738)</u>

Unrestricted – The difference in the change/variance of Total Assets, Total Liabilities and Invested in Capital Assets from June to July 2008 is \$(1,386,481).

Statement of Revenues, Expenditures and Changes in Net Assets

REVENUE

Leo J. Vander Lans Water Treatment Facility – Decreased about \$230,000 due to receiving payment for July in June 2008.

EXPENSES

Connection Fees – Decreased about \$73,000 due to the quarterly wastewater treatment surcharge for Leo J. Vander Lans Water Treatment Facility.

Salaries & Benefits – The decrease of \$237,000 in July from the prior month was the result of an annual fiscal year-end accrual of payroll expense. This accrual only happens on June 30 of each year and is a standard accounting procedure of properly recognizing payroll expense in the proper fiscal year.

Post Employment Benefits – The decrease of \$456,000 in July is due to the annual required recognition of Other Post Employment Benefit (OPEB) obligations in accordance with GASB 45. This will be a yearly entry based on the Annual Required Contribution (ARC) as calculated by an independent actuarial study.

Professional Services – The WRD recognized more expenses related to professional services in June in order to post the costs in the proper fiscal year. The expenses decreased in July back to normal levels.

Other General and Administrative Expenses – The decrease of \$425,000 was due to a bi-annual accrual of election expense related to our obligation to the County Registrar of Voters for conducting the election of our Board members.

FISCAL IMPACT

None.

STAFF RECOMMENDATION

Approve the Financial Statements for July 31, 2008.

Water Replenishment District of Southern California
Statement of Net Assets
July 31, 2008

Assets	Total	Prior Month Total	Variance
Current Assets			
Cash and Cash Equivalents	\$ 14,847,268	\$ 15,378,959	(531,691)
Restricted Cash	10,447,034	10,361,203	85,832
Accounts Receivable	7,911,423	7,099,628	811,795
Deposits Receivable	144,005	144,005	-
Interest Receivable	26,487	121,080	(94,592)
Prepaid Expenses	158,119	63,105	95,014
Total Current Assets	\$ 33,534,337	\$ 33,167,979	366,358
Noncurrent Assets			
Notes Receivable, Noncurrent	\$ 1,785,513	\$ 1,847,646	(62,133)
Plant & Equipment	60,886,082	60,886,082	-
Land	2,644,753	2,644,753	-
Construction-In-Progress	4,141,670	4,014,652	127,018
Deferred Charges	459,775	459,775	-
Accumulated Depreciation	(11,336,761)	(11,148,005)	(188,756)
Total Noncurrent Assets	\$ 58,581,032	\$ 58,704,903	(123,871)
Total Assets	\$ 92,115,369	\$ 91,872,883	242,486
Liabilities			
Current Liabilities			
Accounts Payable	\$ 4,963,863	\$ 5,344,702	(380,838)
Interest Payable - Bond	-	269,659	(269,659)
Accrued Payroll	(573)	42,514	(43,086)
Accrued Employee Benefits	1,549	39,558	(38,009)
Accrued Postemployment	455,925	455,925	-
Deferred Compensation	5,325	40,989	(35,664)
Cal Trans 0690	6,291,429	6,291,429	-
Long term Debt - Bond Payable	14,785,000	15,100,000	(315,000)
Other Liabilities	430,400	430,400	-
Total Current Liabilities	\$ 26,932,919	\$ 28,015,176	(1,082,257)
Noncurrent Liabilities			
Compensated Absences	\$ 237,931	\$ 237,931	\$ -
Total Noncurrent Liabilities	\$ 237,931	\$ 237,931	\$ -
Total Liabilities	\$ 27,170,850	\$ 28,253,107	(1,082,257)
Net Assets			
Invested in Capital Assets	\$ 56,335,745	\$ 56,397,483	(61,738)
Unrestricted	8,608,774	7,222,293	1,386,481
Total Net Assets	\$ 64,944,519	\$ 63,619,776	1,324,743
Total Liabilities & Net Assets	\$ 92,115,369	\$ 91,872,883	242,486

Water Replenishment District of Southern California
Statement of Revenues, Expenditures and Changes in Net Assets
For the Month of July 2008

	Total	Prior Month Total	Variance
Revenues			
Operating Revenues			
Water Replenishment Assessments	3,422,835	3,291,104	131,731
Late Payment Penalties	-	-	-
MWD Subsidy	111,856	43,075	68,781
OCWD Recycled Water Product	-	30,227	(30,227)
Desalter Revenue	64,363	83,374	(19,011)
LJVWFT Lease	-	230,433	(230,433)
Title 22 Monitoring Program	29,260	48,894	(19,634)
Total Operating Revenues	3,628,314	3,727,108	(98,794)
Operating Expenses			
Cost of Water			
Spreading	60,312	43,049	17,262
Injected	1,069,841	1,146,041	(76,200)
In-Lieu	-	-	-
Connection Fees	34,990	107,759	(72,769)
Total Cost of Water	1,165,142	1,296,849	(131,706)
General & Administrative			
Salaries, Taxes & Benefits	295,223	531,815	(236,592)
Postemployment Benefits	-	455,925	(455,925)
Conference & Travel	5,328	18,635	(13,307)
Office Expenses	147,622	155,410	(7,788)
Utilities	34,639	34,121	518
Rents & Leases	14,269	5,695	8,574
Repairs & Maintenance	18,881	59,102	(40,221)
Material & Equipment	42,879	27,042	15,838
General Liability Insurance	5,259	5,737	(478)
Professional Fees	413,803	692,590	(278,787)
Other General & Administrative	-	425,400	(425,400)
Total General & Administrative	977,903	2,411,471	(1,433,568)
Depreciation	188,756	593,765	(405,009)
Total Operating Expenses	2,331,801	4,302,085	(1,970,283)
Operating Income (Loss)	1,296,513	(574,977)	1,871,490
Non-Operating Revenues (Expenses)			
Revenues			
Property Taxes	-	17,921	(17,921)
Investment Earnings	60,922	90,797	(29,875)
Miscellaneous	4,500	(6,172)	10,672
Total Non-Operating Revenues (Expenses)	65,422	102,546	(37,124)
Income (Loss) Before Contributions	1,361,935	(472,431)	1,834,365
Contributions			
Capital Contributions- Caltran Grant		41,465	(41,465)
Change in Net Assets	1,361,935	(430,966)	1,792,900



MEMORANDUM

ITEM NO. 7

Prepared by: Scott M. Ota

Reviewed by: Scott M. Ota

Approved by: Robb Whitaker

DATE: OCTOBER 27, 2008

TO: FINANCE COMMITTEE

FROM: ROBB WHITAKER, GENERAL MANAGER

SUBJECT: INVESTMENT REPORT FOR THE PERIOD ENDING JULY 31, 2008

Each month, the Finance Department reports the investment activities of the District to the Finance Committee for subsequent approval by the Board of Directors. Staff has attached the investment report for July 31, 2008 for approval by the Finance Committee.

FISCAL IMPACT

None.

STAFF RECOMMENDATION

Approve the Investment Report for the period ending July 31, 2008.

Water Replenishment District Investment Type Breakdown as of July 31, 2008

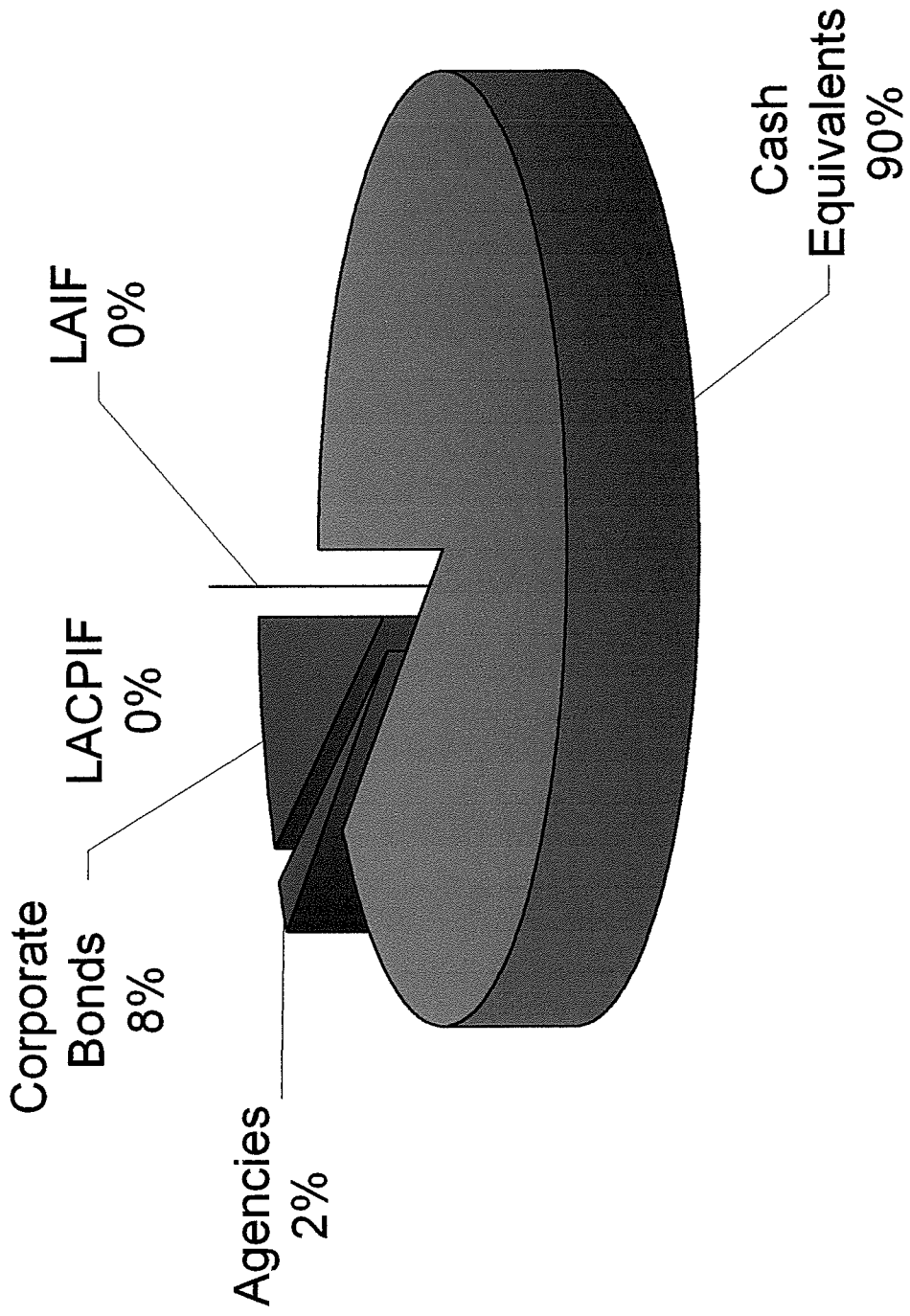

Water Replenishment District Cash & Investments

July 31, 2008

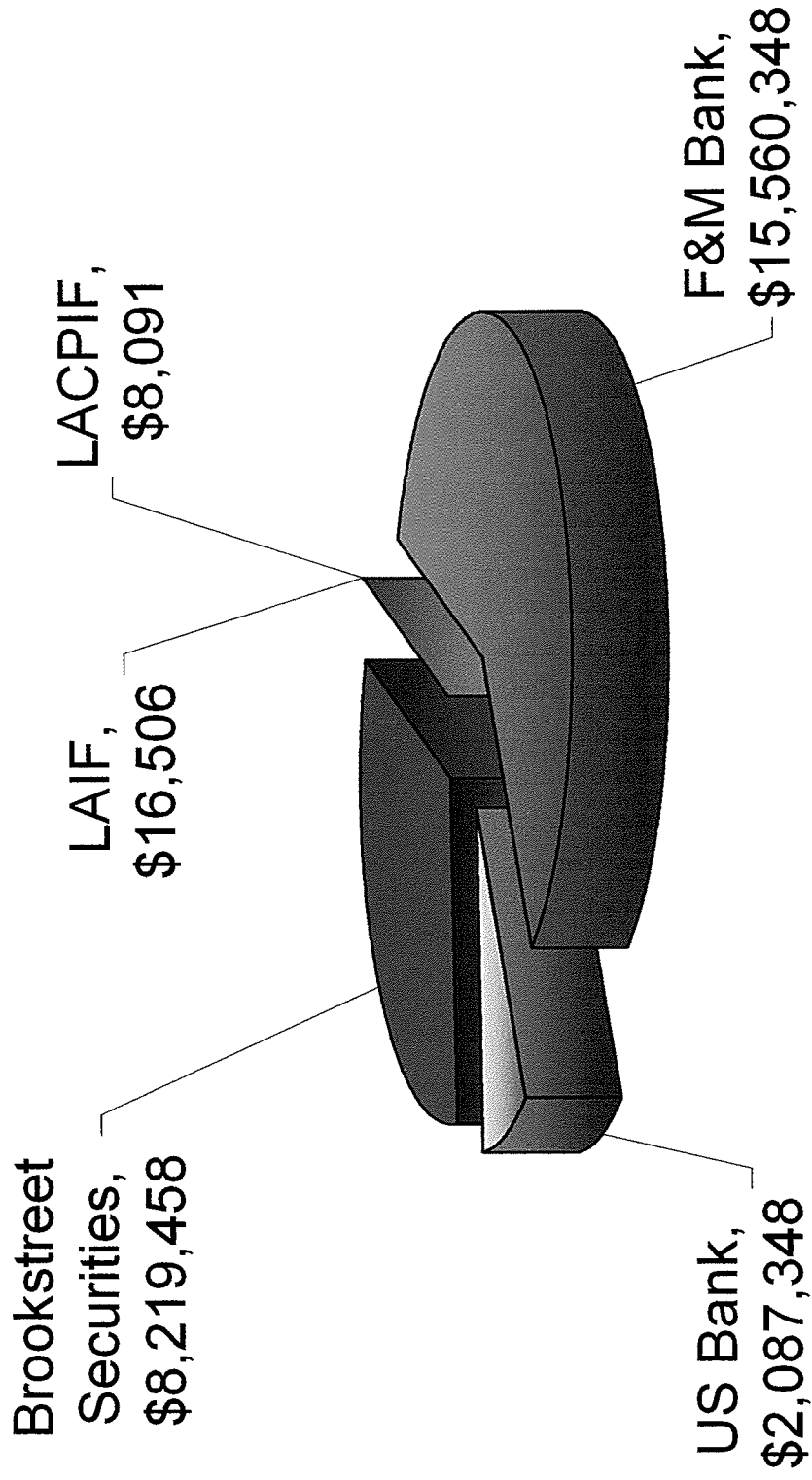



MEMORANDUM

ITEM NO. 8

*Prepared by: Abbie Andom
Reviewed by: Scott Ota
Approved by: Robb Whitaker*

DATE: OCTOBER 27, 2008

TO: FINANCE COMMITTEE

FROM: ROBB WHITAKER, GENERAL MANAGER

SUBJECT: CONSIDERATION OF RESOLUTION NO. 08- 821– A JOINT RESOLUTION OF THE BOARD OF SUPERVISORS OF THE COUNTY OF LOS ANGELES ACTING IN BEHALF OF LOS ANGELES COUNTY GENERAL FUND, LOS ANGELES COUNTY FLOOD CONTROL, THE BOARD OF DIRECTORS OF COUNTY SANITATION DISTRICT NO. 5 OF LOS ANGELES COUNTY, AND THE GOVERNING BODIES OF LOS ANGELES COUNTY WEST VECTOR CONTROL DISTRICT, CITY OF EL SEGUNDO, AND THE WATER REPLENISHMENT DISTRICT OF SOUTHERN CALIFORNIA APPROVING AND ACCEPTING NEGOTIATED EXCHANGE OF PROPERTY TAX REVENUES RESULTING FROM ANNEXATION TO COUNTY SANITATION DISTRICT NO. 5 – ANNEXATION NO. 55

SUMMARY

A request has been received from the County Sanitation Districts of Los Angeles County regarding tax sharing resolutions.

FISCAL IMPACT

None.

FINANCE COMMITTEE RECOMMENDATION

Adopt Resolution No. 08-821.

RESOLUTION NO. 08-821

**A JOINT RESOLUTION OF THE BOARD OF SUPERVISORS
OF THE COUNTY OF LOS ANGELES ACTING IN BEHALF OF
LOS ANGELES COUNTY GENERAL FUND, LOS ANGELES COUNTY FLOOD CONTROL, THE
BOARD OF DIRECTORS OF COUNTY SANITATION DISTRICT NO. 5 OF LOS ANGELES COUNTY,
AND THE GOVERNING BODIES OF LOS ANGELES COUNTY WEST VECTOR CONTROL
DISTRICT, CITY OF EL SEGUNDO, AND THE WATER REPLENISHMENT DISTRICT OF
SOUTHERN CALIFORNIA APPROVING AND ACCEPTING NEGOTIATED EXCHANGE OF
PROPERTY TAX REVENUES RESULTING FROM ANNEXATION TO
COUNTY SANITATION DISTRICT NO. 5**

“ANNEXATION NO. 55”

WHEREAS, pursuant to Section 99 and 99.01 of the Revenue and Taxation Code, prior to the effective date of any jurisdictional change which will result in a special district providing a new service, the governing bodies of all local agencies that receive an apportionment of the property tax from the area must determine the amount of property tax revenues from the annual tax increment to be exchanged between the affected agencies and approve and accept the negotiated exchange of property tax revenues by resolution; and

WHEREAS, the governing bodies of the agencies signatory hereto have made determinations of the amount of property tax revenues from the annual tax increments to be exchanged as a result of the annexation to County Sanitation District No. 5 entitled *Annexation No. 55*;

NOW THEREFORE, BE IT RESOLVED AS FOLLOWS:

1. The negotiated exchange of property tax revenues resulting from the annexation of territory to County Sanitation District No. 5 in the annexation entitled *Annexation No. 55* is approved and accepted.
2. For each fiscal year commencing on and after July 1, 2009, or after the effective date of this jurisdictional change, whichever is later, the County Auditor shall transfer to County Sanitation District No. 5 a total of 0.5537356 percent of the annual tax increment attributable to the land area encompassed within *Annexation No. 55* as shown on the attached Worksheet.
3. No additional transfer of property tax revenues shall be made from any other taxing agencies to County Sanitation District No. 5 as a result of annexation entitled *Annexation No. 55*.
4. No transfer of property tax increments from properties within a community redevelopment project which are legally committed to a Community Redevelopment Agency, shall be made during the period that such tax increment is legally committed for repayment of the redevelopment project costs.
5. If at any time after the effective date of this resolution, the calculations used herein to determine initial property tax transfers or the data used to perform those calculations are found to be incorrect thus producing an improper or inaccurate property tax transfer, the

property tax transfer shall be recalculated and the corrected transfer shall be implemented for the next fiscal year, and any amounts of property tax received in excess of that which is proper shall be refunded to the appropriate agency.

The foregoing resolution was adopted by the Board of Supervisors of the County of Los Angeles, the Board of Directors of County Sanitation District No. 5 of Los Angeles County, and the governing bodies of Los Angeles County West Vector Control District, City of El Segundo, and Water Replenishment District of Southern California, signatory hereto.

WATER REPLENISHMENT DISTRICT OF
SOUTHERN CALIFORNIA

Robert Katherman, President

ATTEST:

Willard H. Murray, Jr., Secretary

Date



MEMORANDUM

ITEM NO. 9

Prepared by: Abbie Andom

Reviewed by: Scott M. Ota

Approved by: Robb Whitaker

DATE: OCTOBER 27, 2008

TO: BOARD OF DIRECTORS

FROM: ROBB WHITAKER, GENERAL MANAGER

**SUBJECT: CONSIDERATION OF RESOLUTION NO. 08- 837 –
A JOINT RESOLUTION OF THE BOARD OF SUPERVISORS OF THE
COUNTY OF LOS ANGELES; THE BOARD OF DIRECTORS OF THE
GREATER LOS ANGELES COUNTY VECTOR CONTROL DISTRICT; THE
BOARD OF DIRECTORS OF THE COUNTY SANITATION DISTRICT NO. 8
OF LOS ANGELES COUNTY (COUNTY SANITATION DISTRICT NO. 8); THE
CITY COUNCIL OF THE CITY OF CARSON; AND THE BOARD OF
DIRECTORS OF THE WATER REPLENISHMENT DISTRICT OF SOUTHERN
CALIFORNIA APPROVING AND ACCEPTING THE NEGOTIATED
EXCHANGE OF PROPERTY TAX REVENUES RESULTING FROM
ANNEXATION OF L 035-2008 INTO COUNTY LIGHTING MAINTENANCE
DISTRICT 1697**

SUMMARY

A request has been received from the County of Los Angeles Department of Public Works regarding participation in the exchange of ad valorem property tax. If a taxing agency involved in the negotiation does not adopt a resolution providing for the exchange of property tax, the Board of Supervisors can determine the exchange of property tax revenue for that taxing agency.

FISCAL IMPACT

None.

STAFF RECOMMENDATION

Adopt Resolution No. 08-837.

RESOLUTION NO. 08-837

A JOINT RESOLUTION OF THE BOARD OF SUPERVISORS OF THE COUNTY OF LOS ANGELES; THE BOARD OF DIRECTORS OF THE GREATER LOS ANGELES COUNTY VECTOR CONTROL DISTRICT; THE BOARD OF DIRECTORS OF THE COUNTY SANITATION DISTRICT NO. 8 OF LOS ANGELES COUNTY (COUNTY SANITATION DISTRICT NO. 8); THE CITY COUNCIL OF THE CITY OF CARSON; AND THE BOARD OF DIRECTORS OF THE WATER REPLENISHMENT DISTRICT OF SOUTHERN CALIFORNIA APPROVING AND ACCEPTING THE NEGOTIATED EXCHANGE OF PROPERTY TAX REVENUES RESULTING FROM ANNEXATION OF L 035-2008 TO COUNTY LIGHTING MAINTENANCE DISTRICT 1697

WHEREAS, pursuant to Section 99.01 of the Revenue and Taxation Code, prior to the effective date of any jurisdictional change that will result in a special district providing one or more services to an area where those services have not previously been provided by any local agency, the special district and each local agency that receives an apportionment of property tax revenue from the area must negotiate an exchange of property tax increment generated in the area subject to the jurisdictional change and attributable to those local agencies; and

WHEREAS, the Board of Supervisors of the County of Los Angeles, acting on behalf of the County Lighting Maintenance District 1697, the Los Angeles County General Fund, the Los Angeles County Library, the Consolidated Fire Protection District of Los Angeles County, the Los Angeles County Flood Control Drainage Improvement maintenance District, and the Los Angeles County Flood Control District; the Board of Directors of the Greater Los Angeles County Vector Control District; the Board of Directors of the County Sanitation District No.8 of Los Angeles County (County Sanitation District No. 8), the City Council of the City of Carson; and the Board of Directors of the Water Replenishment District of Southern California have determined that the amount of property tax revenue to be exchanged between their respective agencies as a result of the annexation proposal identified as L 035-2008 into County Lighting Maintenance District 1697 is as shown on the attached Property Tax Transfer Resolution Worksheets.

NOW, THEREFORE, BE IT RESOLVED AS FOLLOWS:

1. The negotiated exchange of property tax revenues between the County Lighting Maintenance District 1697, and the Los Angeles County General Fund, the Los Angeles County Library, the Consolidated Fire Protection District of Los Angeles County, the Los Angeles County Flood Control Drainage Improvement Maintenance District, the Los Angeles County Flood Control District, the Greater Los Angeles County Vector Control District, the County Sanitation District No.8, the City of Carson, and the Water Replenishment District of Southern California resulting from the annexation proposal identified as L 035-2008 into County Lighting Maintenance District 1697 is approved and accepted.
2. For fiscal years commencing on or after July 1, 2008, or the July 1 after the effective date of this jurisdictional change, whichever is later, the property tax revenue increment generated from the area within L 035-2008 (Tax Rate Area's

01045 and 01001) shall be allocated to the affected agencies as indicated in the enclosed Property Tax Transfer Resolution Worksheets.

3. No transfer of property tax revenues other than those specified in Paragraph 2 shall be made as a result of annexation of L 035-2008.
4. If at any time after the effective date of this Resolution, the calculations used herein to determine initial property tax transfers or the data used to perform those calculations are found to be incorrect, thus producing an improper or inaccurate property tax transfer, the property tax transfer shall be recalculated and the corrected transfer shall be implemented for the next fiscal year, and any amounts of property tax received in excess of that which is proper shall be refunded to the appropriate agency.

PASSED, APPROVED AND ADOPTED THIS _____ day of _____, 2008 by the following vote:

AYES:
NOES:
ABSENT:
ABSTAIN:

WATER REPLENISHMENT DISTRICT OF SOUTHERN CALIFORNIA

Robert Katherman, President

ATTEST:

Willard H. Murray, Jr., Secretary

Date